

BUILT-IN REFRIGERATION

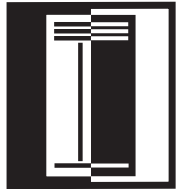

USE & CARE INFORMATION





CONTENTS

Sub-Zero Built-In Refrigeration	3
Sub-Zero Built-In Features	4
Sub-Zero Built-In Models	5
Sub-Zero Built-In Use & Care	12
Keeping Food at Its Best	25
Food Storage Recommendations	29
Troubleshooting Guide	35
Service Information	38
Sub-Zero Warranty	39

As you read this Use & Care Information, take particular note of the CAUTION and WARNING symbols when they appear. This information is important for safe and efficient use of the Sub-Zero equipment.

▲ CAUTION

signals a situation where minor injury or product damage may occur if you do not follow instructions.

▲ WARNING

states a hazard that may cause serious injury or death if precautions are not followed.

In addition, this Use & Care Information may signal an IMPORTANT NOTE which highlights information that is especially important.



THANK YOU

Thank you for purchasing your new Sub-Zero Built-In unit. With Sub-Zero, you can rely on a 60-year tradition of quality and reliability. The Built-In line brings together the latest and finest features in home refrigeration to give you the freshest food possible.

Sub-Zero's design, beauty and quality are reflected in the broad range of standard features that put Sub-Zero in a class by itself. The custom-design appearance of the Sub-Zero Built-In line gives you options no other line offers, whether you have chosen a framed, overlay, stainless steel or glass door style unit.

Your Sub-Zero is protected by a warranty that is one of the finest in the industry. Take a moment to read the warranty statement on page 39 and refer to it should service become necessary.

This Use & Care Information book will answer most of your questions about the features, operation and maintenance of your Built-In unit. If you have questions that are not addressed here, call Sub-Zero Customer Service at 800-222-7820 or visit our website, subzero.com.

DUAL REFRIGERATION

The Built-In line continues the Sub-Zero tradition of superior quality and reliability. Sub-Zero pioneered the development of our exclusive dual refrigeration system, giving you optimum fresh and freezer food storage in ideal self-contained sections. Both refrigerator and freezer maintain accurate, consistent temperatures. Dual refrigeration keeps your food fresh longer than any other system available.

With dual refrigeration, the freezer maintains a constant temperature within one degree of the temperature you set within our range of -5°F (-21°C) to +5°F (-15°C), without unwanted moisture and odor from the refrigerator. Similarly, you can adjust the refrigerator temperature within a range of 34°F (1°C) to 45°F (7°C), for proper humidity levels tailored for longer food life expectancy.

The dual refrigeration system also means there is no transfer of fresh food odors to frozen food or ice. The Sub-Zero system does not freeze the moisture out of the air in the fresh food section.

Sub-Zero dual refrigeration is also more energy efficient than old-fashioned single refrigeration systems. When the refrigerator is used frequently during the day it does not require the freezer to circulate its very cold, dry air to the refrigerator. Instead, the refrigerator uses moist air to keep fresh foods fresh and energy use minimal.

CONTACT INFORMATION

**Sub-Zero
Customer Service:
800-222-7820**

**Website:
subzero.com**



BUILT-IN FEATURES

ACCESSORIES

Optional accessories are available through your Sub-Zero dealer. To obtain local dealer information, visit the Locator section of our website, subzero.com.

- Classic framed models—the look that made Sub-Zero famous—feature an advanced grille design, innovative handle design and elegant hinges.
- Overlay models blend seamlessly into your overall room design and complement surrounding cabinetry.
- Classic stainless steel or the premium finishes of platinum or carbon stainless steel models feature new wrapped doors, 1" (25 mm) diameter stainless steel handles and stainless steel grille designed specifically to enhance the aesthetics of today's professional looking kitchens.
- Models 601RG, 611G and 650G offer a unique feature—a glass door. These units each come in the framed or overlay design, or classic, platinum or carbon stainless steel, and meet stringent energy requirements.
- Glass door models add a contemporary look that is quite unique and innovative, with subdued interior lighting.
- Shallow-depth design means access is easy to any area of the refrigerator.
- All Built-In combination refrigerator/freezer units have the exclusive Sub-Zero dual refrigeration system, which ensures the freshest food and energy efficiency at the same time. You have precise independent control of the refrigerator and freezer sections.
- All Built-In units have a microprocessor to give you better control, automatic defrosting that senses, then adapts to your use patterns, and a service indicator light. Our microprocessor continuously monitors each section, and should a problem arise, the processor will turn on the SERVICE indicator light in the Control Center display panel.
- Controls are up front and easy to use. They give you digital readings for quick, easy-to-read reference. Up-front controls also keep you informed about the operation of the unit on a continuous basis.
- Bright lighting spreads even illumination throughout each section. The source of the illumination is concealed.
- A door alarm will let you know with an audible beeping if your refrigerator or freezer door is left ajar.
- The high humidity crisper drawer is large and deep, with smooth sides for easy cleaning. The compartment features removable dividers, with the exception of Models 661, 642 and 685.
- The cantilevered shelves make repositioning quick and easy. They're easy to clean and spill proof. They are steel reinforced to provide durability and reliability.
- In-door shelves are all adjustable for complete flexibility.
- The dairy compartment is adjustable, with easy, one-door access, compartment dividers and a clean design. The dairy shelf is magnetically sealed to maintain freshness.
- Models 611, 611G, 650 and 650G offer a full-extension freezer drawer.
- The ice maker provides high-quality, crescent-shaped ice that won't stick to the side of the glass.
- Magnetic gaskets around all doors give extra-tight seals.
- Our solid-core doors improve insulation and structural integrity.
- Solid, adjustable kickplate gives a true built-in look and conforms to American Institute of Architects standards.



With the installation of a harness kit, these appliances are Star-K compliant to meet strict religious regulations in conjunction with specific instructions found on www.star-k.org. For details about the harness kit, contact your Sub-Zero dealer.



MODEL 60IR
ALL REFRIGERATOR

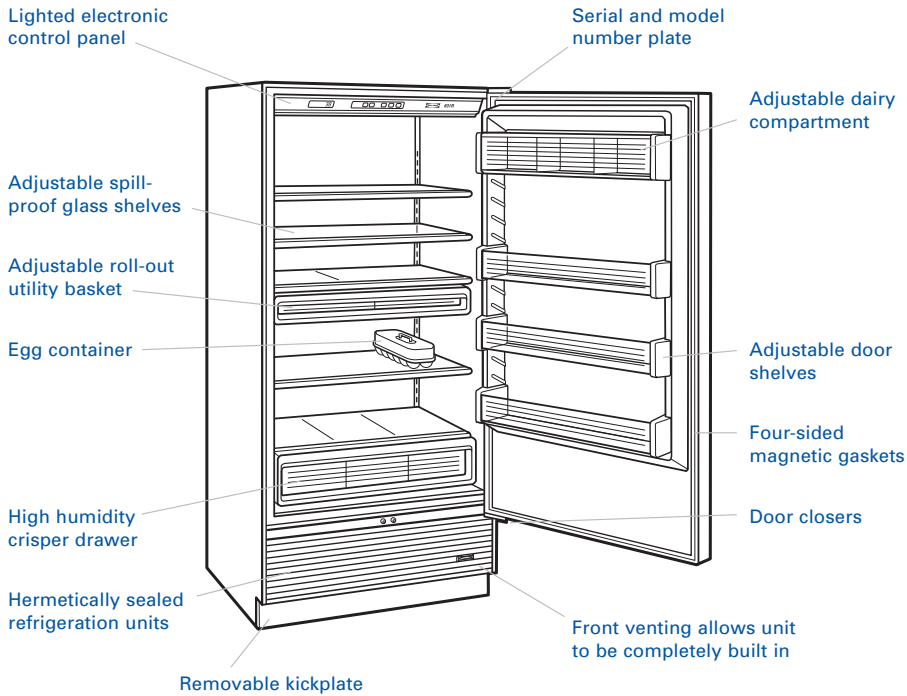

WARRANTY

Sub-Zero products are covered by a two, five and twelve year residential warranty (exclusions apply). See warranty details at the end of this guide.

MODEL 60IRG
ALL REFRIGERATOR WITH GLASS DOOR

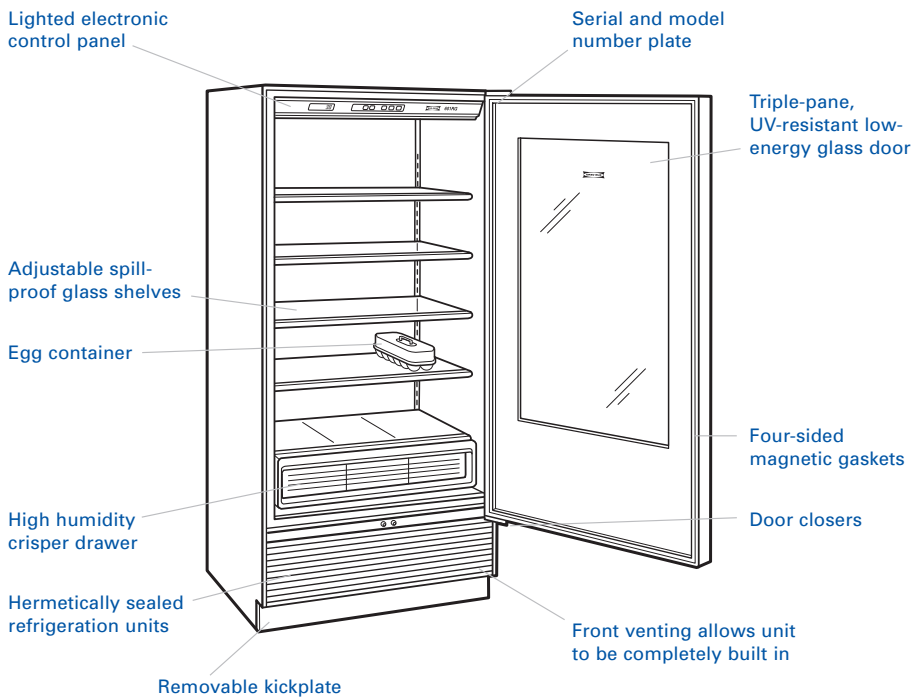



SUB-ZERO **BUILT-IN** MODELS

MODEL 60IF
ALL FREEZER

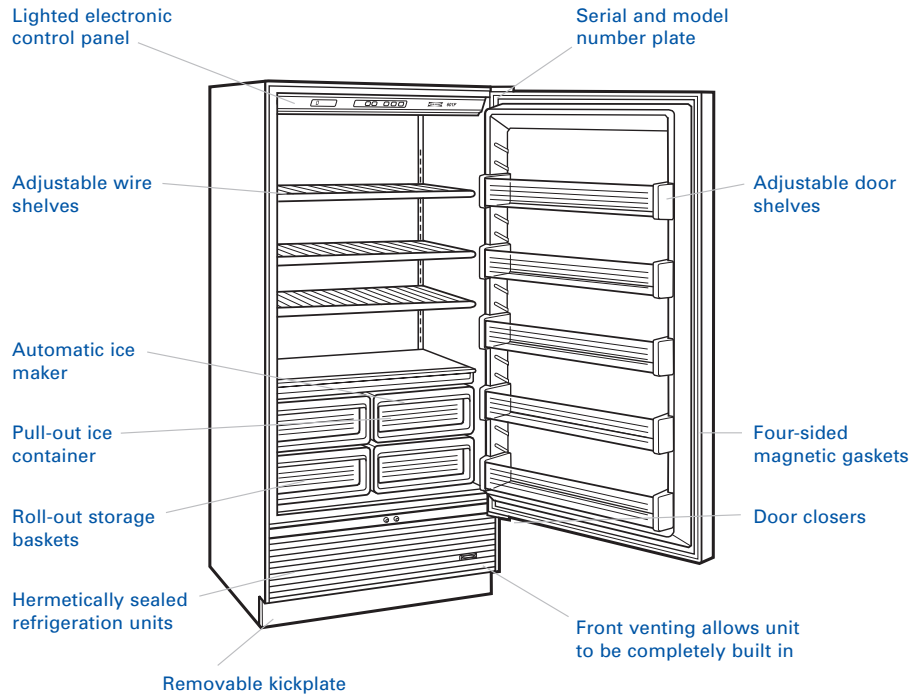



MODEL 611
OVER-AND-UNDER REFRIGERATOR | FREEZER

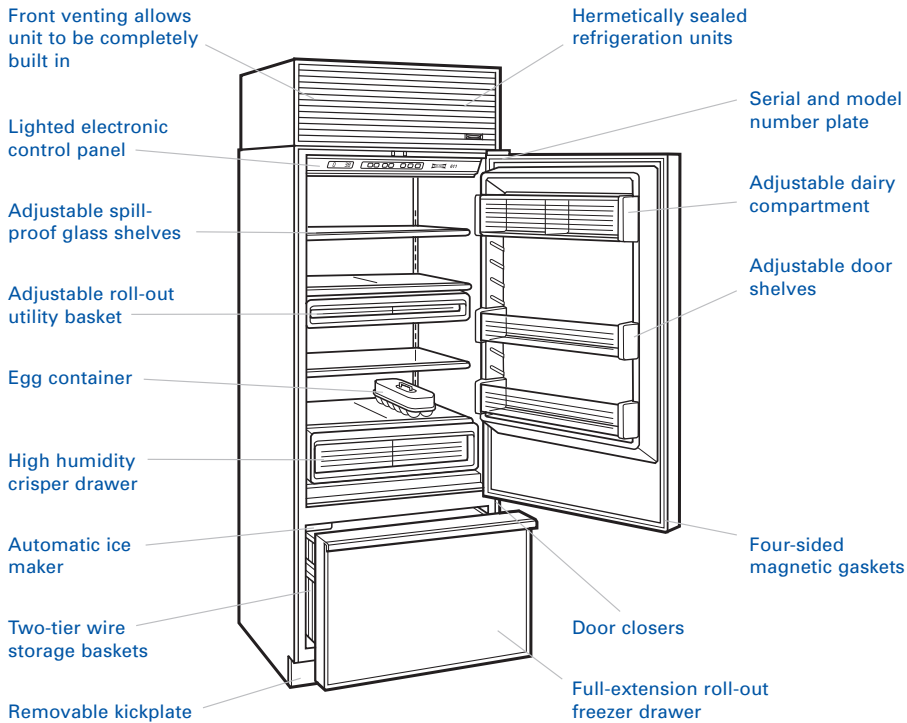

MODEL 611G
OVER-AND-UNDER WITH GLASS DOOR

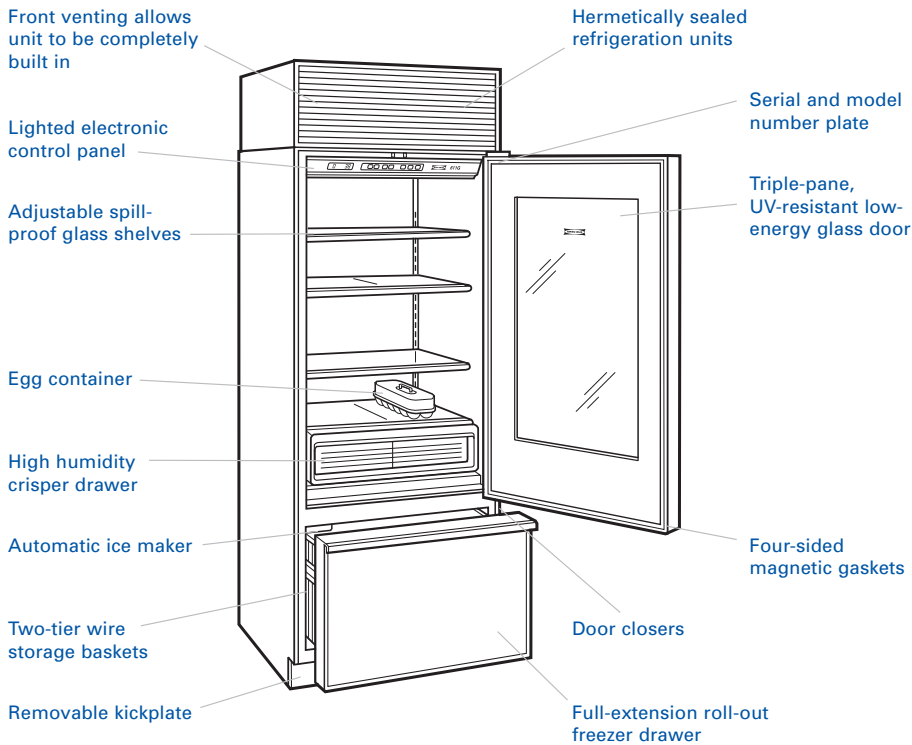



SUB-ZERO **BUILT-IN** MODELS

MODEL 650
OVER-AND-UNDER REFRIGERATOR | FREEZER

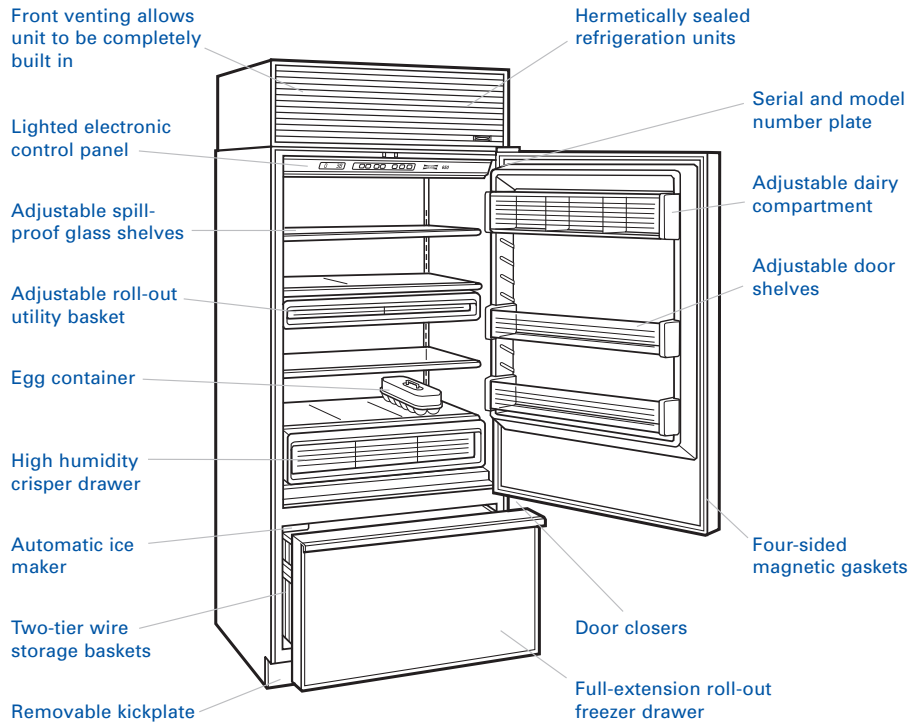

MODEL 650G
OVER-AND-UNDER WITH GLASS DOOR

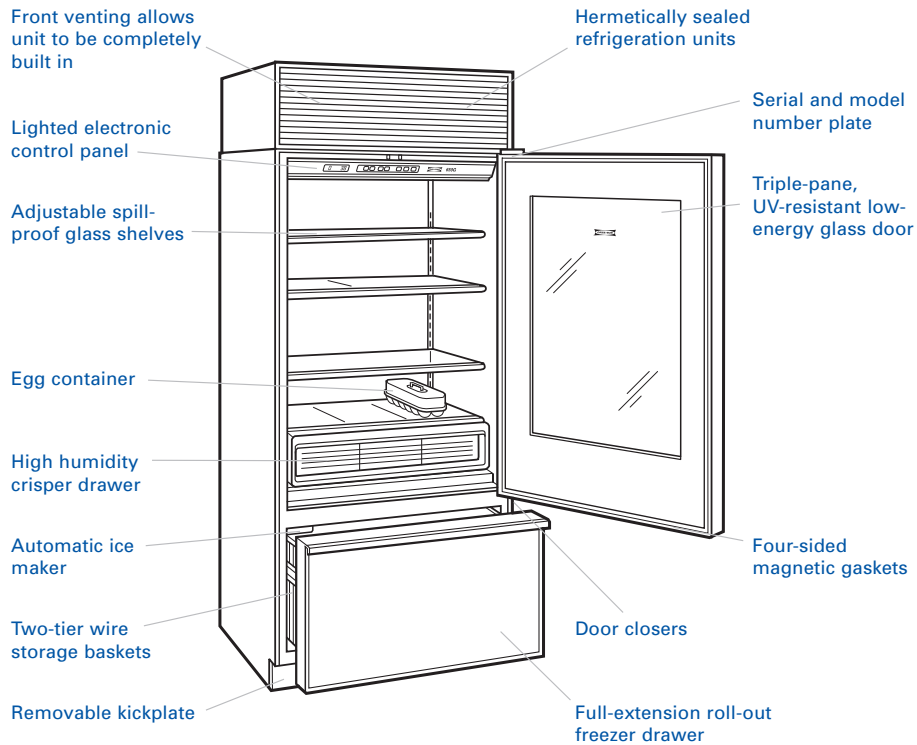



MODEL 661
SIDE-BY-SIDE REFRIGERATOR | FREEZER

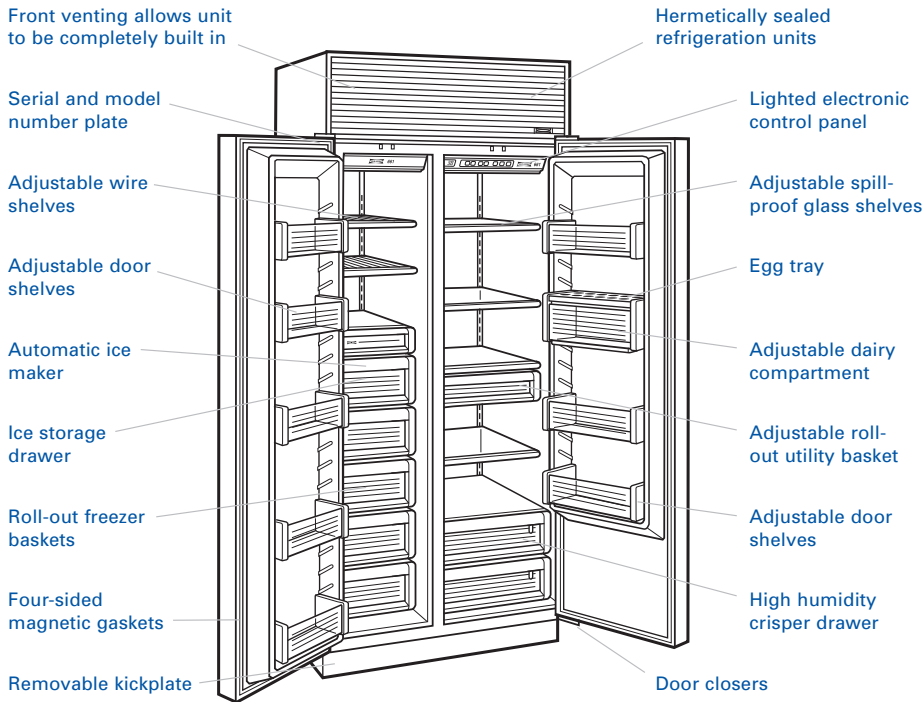

MODEL 642
SIDE-BY-SIDE REFRIGERATOR | FREEZER

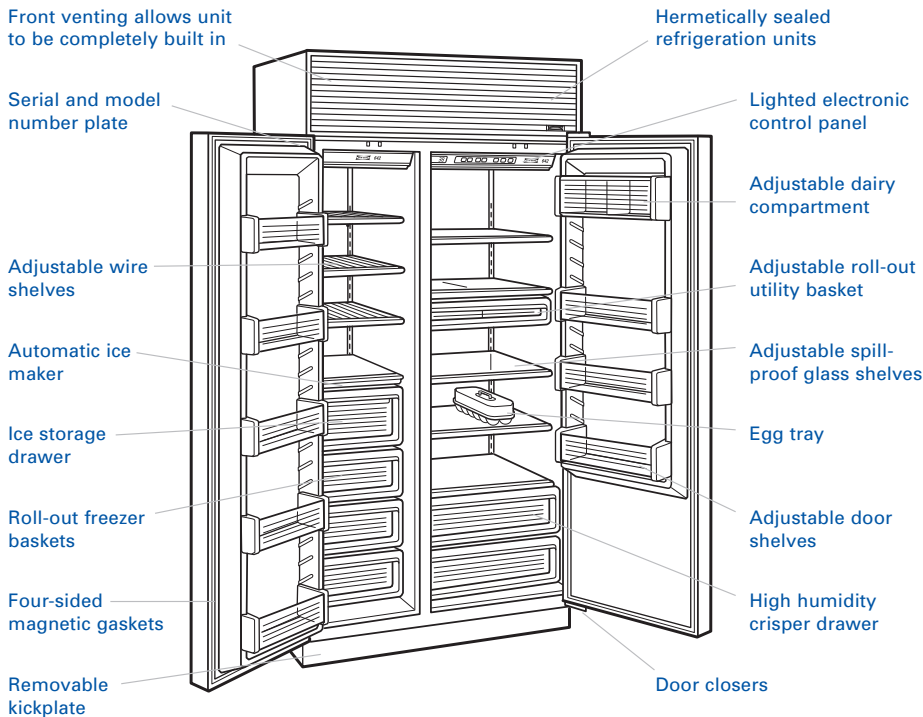



SUB-ZERO **BUILT-IN** MODELS

MODEL 685

SIDE-BY-SIDE WITH ICE | WATER DISPENSING

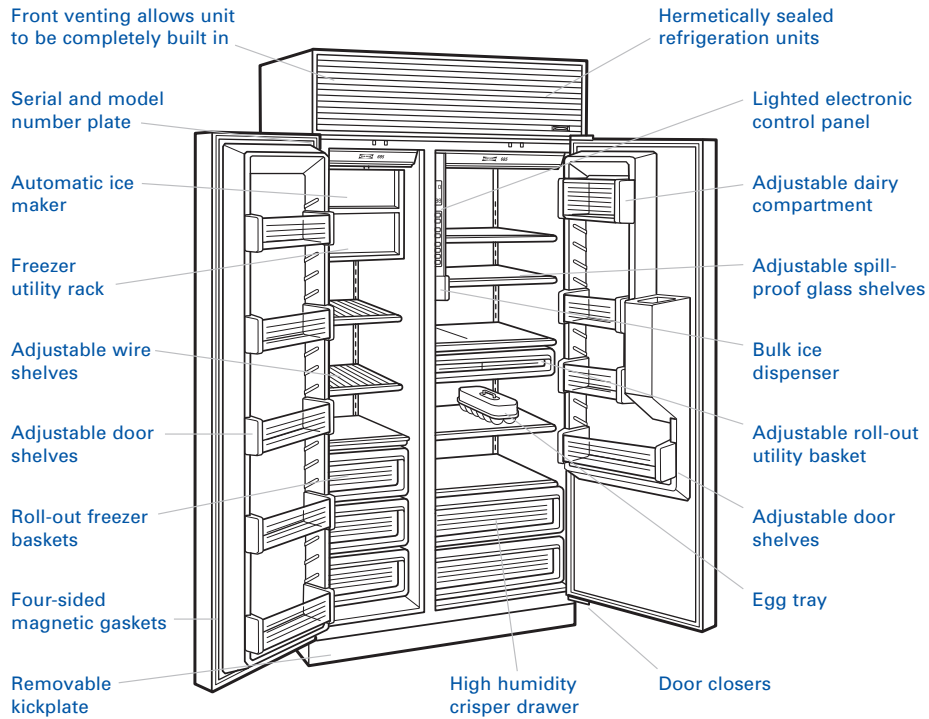

MODEL 632

SIDE-BY-SIDE REFRIGERATOR | FREEZER

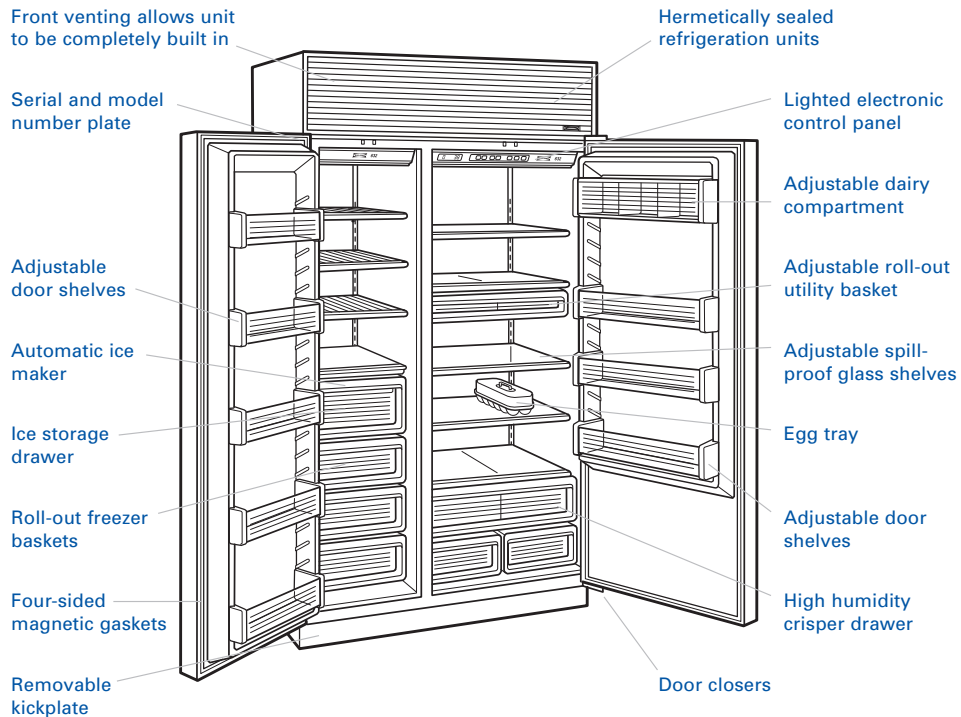



MODEL 695

SIDE-BY-SIDE WITH ICE | WATER DISPENSING

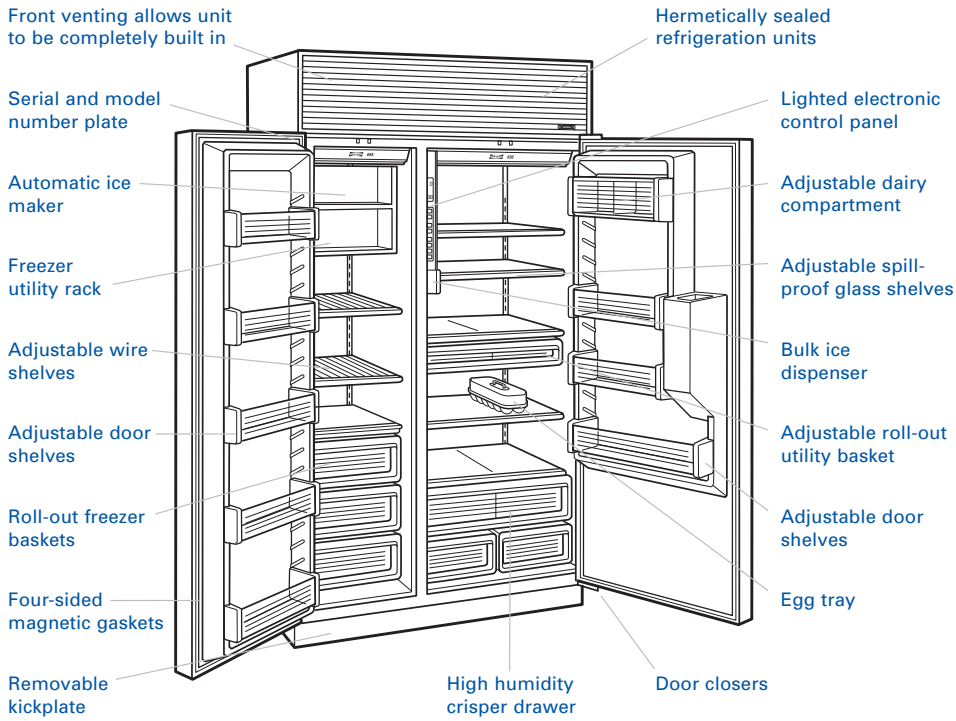



ELECTRONIC CONTROL SYSTEM

The Electronic Control System of your Sub-Zero Built-In unit monitors and accurately displays temperatures within one degree of your preset temperature. It also monitors operation of the unit and lets you know if there's a problem. You'll find the Control Center located in the refrigerator section of all models, except Model 601F where it is in the freezer section. Refer to the illustrations below.

TEMPERATURE CONTROL

Your new refrigerator/freezer was thoroughly inspected and tested before it was shipped from the Sub-Zero factory. Temperatures are preset at 38°F (3°C) in the refrigerator section and 0°F (-18°C) in the freezer section.

For combination units, there are two sets of **WARMER** and **COLDER** key pads on the Control Center, one for the refrigerator section and the other for the freezer section. Models 601R, 601RG and 601F have only one set of **WARMER** and **COLDER** key pads.

To adjust the temperature in either section, depress the **WARMER** or **COLDER** key pads on the Control Center.

The temperature ranges are -5°F (-21°C) to +5°F (-15°C) in the freezer section, and 34°F (1°C) to 45°F (7°C) in the refrigerator section. It is normal for temperatures to fluctuate slightly, depending on external influences such as an open door, the degree of humidity and room temperature.

IMPORTANT NOTE: Always allow 24 hours for the refrigerator to reach the temperature you set.

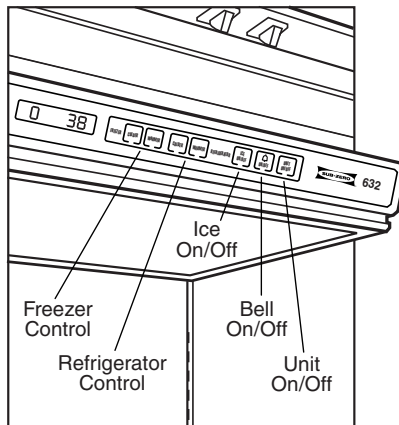

Electronic Control Center

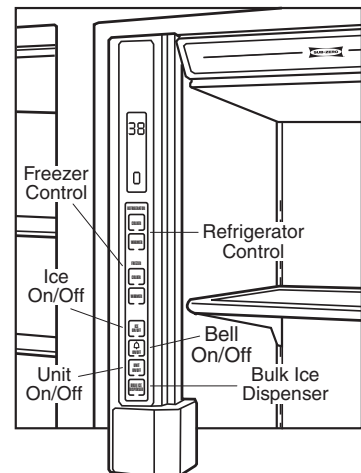

**Electronic Control Center –
Models 685 and 695**



POWER

All Built-In units feature a **UNIT ON/OFF** key pad on the Control Center. This key pad will turn off all electrical power to the unit. When the power is off, the OFF indicator light will be visible in the Control Center display panel. This **UNIT ON/OFF** key pad means you don't have to shut off power at the circuit breaker or wall receptacle. The key pad can be used during service or extended vacations.

ALARM FEATURE

All Built-In units have an alarm feature that will make an audible beeping sound if the door is left ajar.

The alarm will sound after 30 seconds. It can be deactivated for cleaning or resupplying your unit by depressing the "**BELL**" **ON/OFF** key pad. When the alarm is activated, a bell symbol will be visible in the Control Center display panel.

ICE MAKER CONTROL

All Built-In units (except Models 601R and 601RG) feature an **ICE ON/OFF** key pad on the Control Center. This key pad switches the power to the ice maker system on or off. When the ice maker system is on, the ICE indicator light will be illuminated in the Control Center display panel. Use the **ICE ON/OFF** key pad to shut down the ice maker during extended vacations.

SABBATH MODE (STAR-K)

All Built-In units feature the Sabbath Mode. This is for certain religious observances where the lights and ice maker function need to be turned off.

To initiate Sabbath Mode, while the unit is on press the **UNIT ON/OFF** key pad so that OFF is visible in the Control Center display panel. Your unit will be off.

Then press and hold the **UNIT ON/OFF** key pad for 10 seconds. This will turn the unit back on and will disable the lights and ice maker. To return the unit to normal operating conditions, press and release the **UNIT ON/OFF** key pad.

If you have questions about Star-K compliance, visit www.star-k.org.

VISUAL SERVICE DISPLAY

The Control Center monitors refrigerator and freezer temperatures as well as the ice maker system. If there is a temperature or ice maker problem, you'll be alerted by a flashing SERVICE indicator light. This same SERVICE light will also flash if the condenser needs cleaning. Before calling for service, please check and see if your condenser area needs cleaning. Refer to Condenser Cleaning, page 22.



REFRIGERATOR STORAGE

HIGH HUMIDITY CRISPER DRAWER

To remove your high humidity crisper drawer, pull open until the drawer stops. Now raise the front of the drawer and pull it out. To reinstall, insert the drawer into the tracks with the front end raised. Refer to the illustration below. Some units also have other storage drawers, which can be removed in a similar manner.

ACCESSORIES

Optional accessories are available through your Sub-Zero dealer. To obtain local dealer information, visit the Locator section of our website, subzero.com.

ADJUSTABLE GLASS SHELVES

Be sure to read and understand the following instructions before removing or adjusting shelves. To remove or adjust shelves, first tilt the shelf up at the front, then lift it up and out of the tracks on the rear wall of the refrigerator. Refer to the illustration below.

If the door is limited to a 90-degree opening, you'll need to clear the door shelves in order to remove a shelf. Lift and pivot the end of the shelf nearest the door upward, and remove.

To replace a shelf, insert it in the tracks at the rear of the refrigerator with the front of the shelf raised slightly. As you push the shelf in, lower the front of the shelf until it locks into position.

IMPORTANT NOTE: Always be careful in handling glass shelves to prevent breaking or scratching the interior.

⚠ CAUTION

Glass shelves should warm to room temperature before immersing in warm water.

ROLL-OUT UTILITY BASKET

The utility basket rolls in and out so that you can get to small containers and food items easily. To remove the basket, pull it out, lift up on the front, then out. Refer to the illustration below.

To replace the basket, insert the roller into its tracks with the front of the basket raised, and push in.

If the door is limited to a 90-degree opening, you'll need to remove the entire utility basket and shelf as one unit in order to clear the door shelves. To do this, place one hand, palm up, under the basket and lift it out of the support tracks. Pivot the end of the basket assembly nearest the door upward, and remove.

The utility basket is available as an option on Models 601RG, 611G and 650G. Contact your Sub-Zero dealer for details.

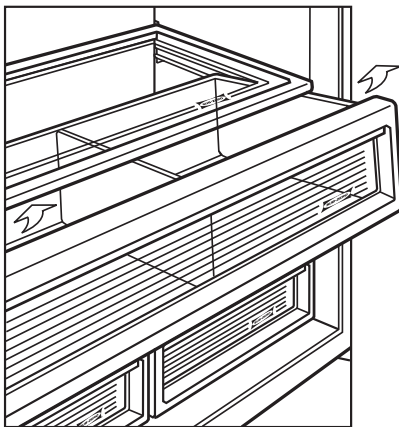

High humidity crisper drawer removal

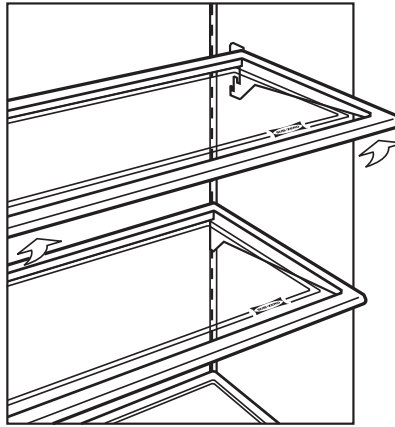

Adjustable glass shelf removal

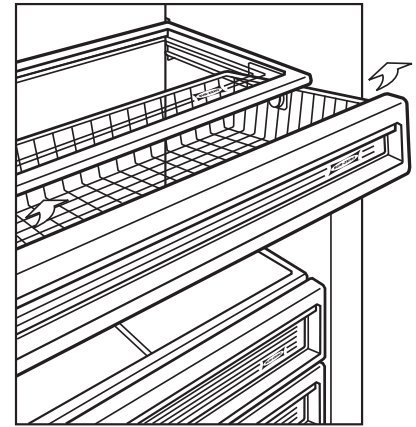

Roll-out utility basket removal



FREEZER STORAGE

DOOR SHELVES AND DAIRY COMPARTMENT

The door shelves and dairy compartment are adjustable within the guides of the door liner.

NOTE: Glass door models do not have door shelves or a dairy compartment.

To remove a shelf or the dairy compartment, lift it up and out from the bottom. To reinstall, push it down into the guides. Refer to the illustration below.

FREEZER BASKET REMOVAL

Models 601F, 661, 642, 685, 632 and 695: First, unload the freezer basket. To remove the basket, pull it out until it stops. Raise the front of the basket and pull it out. Refer to the illustration below.

If the door is limited to a 90-degree opening, pivot the basket away from the door and tilt it up sharply as soon as the rollers leave the tracks. If the basket sticks during removal, lift it up to disengage the rollers. To reinstall the basket, reverse the procedure.

Models 611, 611G, 650 and 650G: First, unload the freezer baskets. To remove the upper freezer basket, lift up on the front and pull forward to release the basket. To remove the lower freezer basket, lift the basket directly upward and out. Refer to the illustration below.

To reinstall the lower freezer basket, insert the basket into the four corner retainers. To reinstall the upper freezer basket, position the basket onto the slide rails. Slide the basket towards the back. You should hear an audible click when the engagement is made.

IMPORTANT NOTE: Unload the freezer baskets before removing.

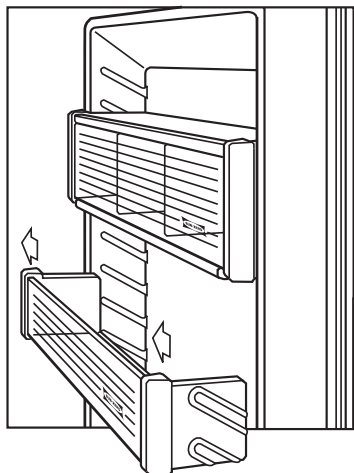

Door shelf removal

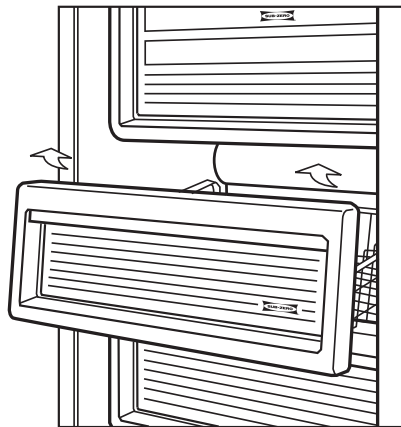

Freezer basket removal – Models 601F, 661, 642, 685, 632 and 695

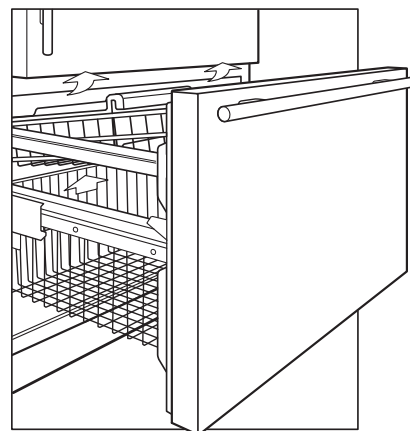

Freezer basket removal – Models 611, 611G, 650 and 650G



FREEZER STORAGE

ICE BUCKET REMOVAL

Models 611, 611G, 650 and 650G: To remove the ice bucket, pull the freezer drawer or basket out until it stops and lift the ice bucket out.

Models 601F, 661, 642 and 632: To remove the ice bucket, pull it out until it stops, and lift the back of the bucket up to clear the carrier assembly. Next, lift the ice bucket out. If the door is limited to a 90-degree opening, repeat the procedure, but when lifting the ice bucket out, pivot the right side of the bucket toward you and out. This will allow the ice bucket to clear the door.

Models 685 and 695: To remove the ice bucket, you must first remove the freezer utility rack. See Freezer Utility Rack, below. Lift up on the ice bucket handle and pull out, supporting the bottom of the ice bucket with one hand. Refer to the illustration below.

FREEZER UTILITY RACK

Models 685 and 695: The freezer utility rack is specifically designed to accommodate and hold frozen juice containers. To remove the rack, lift up and pull out at the bottom with one hand while you support the top with your other hand.

ICE MAKER OPERATION

The ice maker in your Sub-Zero freezer is fully automatic and has been tested at the factory. To start making ice, activate the **ICE ON/OFF** key pad on the Control Center.

For Models 601F, 611, 611G, 650, 650G, 661, 642, 685, 632 and 695, the ice maker system will shut off if the ice bucket is not in place.

ICE PRODUCTION

The ice maker is designed to produce enough ice for normal family use. The timing of ice-making cycles will vary depending on load conditions, door openings and room temperature. On average, you can expect a cycle of ice (eight cubes per cycle) every two hours.

The ice maker operates on water pressure of 20 to 100 psi. In some cases, a reverse osmosis water filter system may not be able to maintain the minimum pressure.

IMPORTANT NOTE: If ice is not used regularly it tends to fuse together. To avoid this, empty and replace the ice in the container as needed.

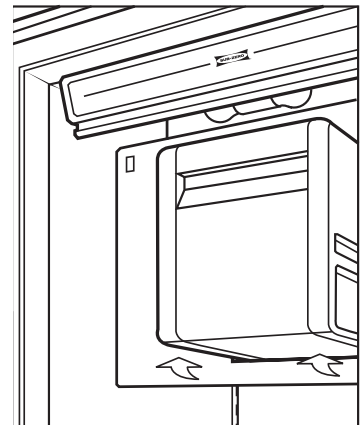

**Ice bucket removal –
Models 685 and 695**



ICE | WATER DISPENSING MODELS

ICE | WATER DISPENSER

For Models 685 and 695, the automatic ice and water dispenser gives you both ice and chilled water without having to open doors.

⚠ CAUTION
Limit continuous ice and/or water dispenser operation to seven minutes or less, to avoid damaging the equipment.

⚠ CAUTION
Use a sturdy glass to catch ice crescents. Fragile glasses can break. Also, to avoid breakage, make sure that the glass is sitting vertically on the water grille.

ICE DISPENSER OPERATION

To operate the ice dispenser for Models 685 and 695, set a glass on the water grille of the glasswell, and press and hold the **ICE** key pad on the glasswell until you have the ice you need. For larger quantities of ice, open the refrigerator door and place an ice container under the dispenser chute, then press the **BULK ICE** key pad on the Control Center. Refer to the illustrations below.

After initial ice maker start-up, discard the first few batches of ice—they may be discolored by the new system plumbing.

WATER DISPENSER OPERATION

To operate the water dispenser for Models 685 and 695, set a glass on the water grille of the glasswell, and press and hold the **WATER** key pad on the glasswell until the glass is filled.

The first time you use the water dispenser, purge the water system and storage tank for three minutes. This will clear out any air in the system, along with foreign material in the new plumbing connection.

Initially, for water to dispense properly, the **WATER** key pad must be depressed and held until water flows from the dispenser. You may have to hold the key pad for 60 seconds for water to fill the internal reservoir tank.

IMPORTANT NOTE: The chilled water reservoir tank is mounted inside the refrigerator section. It will take several hours to chill the water to the refrigerator temperature during the original fill or after a lot of water is used.

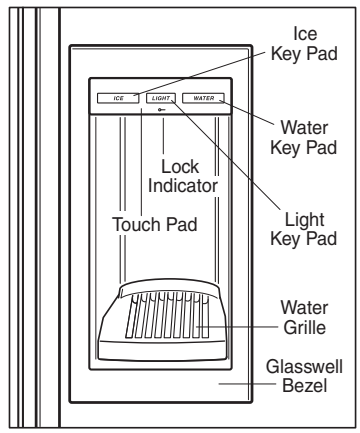

Glasswell – Models 685 and 695

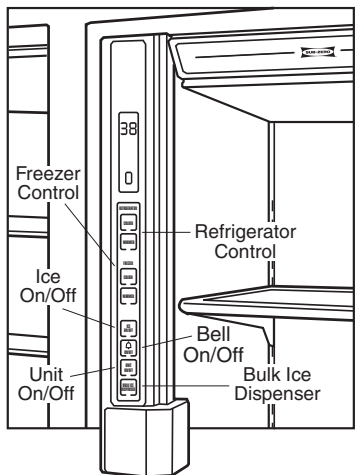

Bulk ice dispenser – Models 685 and 695



ICE | WATER DISPENSING MODELS

DISPENSER LIGHTS

For Models 685 and 695, there are three lighting states that can be cycled by pressing the **LIGHT** key pad on the glasswell.

- All lights OFF
- All lights ON (blue key pad and white glasswell)
- Key pad lights ON only

During water or ice dispensing, all lights will illuminate until dispensing is complete, then lights will return to their previous state.

DISPENSER WATER GRILLE

For Models 685 and 695, a water grille at the base of the glasswell will catch and evaporate small spills. Because there is no drain in this area, do not pour water into the water grille. To clean the area, remove the water grille by pressing the front left corner of the grille and lifting it out.

LOCK

For Models 685 and 695, the lock feature is used to prevent unintended ice and water dispensing. When the dispenser is locked, all key pads on the glasswell are deactivated to allow cleaning or to prevent small children from using the dispenser.

To activate the lock feature, hold down the **LIGHT** key pad on the glasswell until the key pad lights flash once and the red LOCK icon is illuminated (approximately five seconds). The lights will remain in the state they were in before the lock feature was activated.

To deactivate the lock feature, hold down the **LIGHT** key pad until the key pad lights flash once and the red LOCK icon is no longer illuminated (approximately five seconds). The lights will remain in the state they were in before the lock feature was deactivated.

ICE DISPENSING

Models 685 and 695 have a feature that limits the maximum amount of ice that is dispensed each time the **ICE** key pad on the glasswell is pressed.

To dispense ice, hold down the **ICE** key pad for approximately two seconds. The dispenser will meter out ice for about two seconds, collect the ice directly above the glass, then drop the ice into the glass. If less ice is desired, hold the **ICE** key pad down for less than two seconds. If more ice is desired, hold the **ICE** key pad down until the dispensing cycle repeats.

IMPORTANT NOTE: Be sure that dispenser key pads are clean and dry when pressed to avoid problems with the dispenser operation.



VACATION TIME

ICE DISPENSER OPERATING TIPS

- If there's no ice, make sure the ice maker system is turned on and ICE is illuminated in the Control Center display panel.
- Make sure there is a supply of ice in the ice bucket. See Ice Bucket Removal, page 16.
- Make sure the ice bucket is all the way in and engaging the auger motor at the back of the bucket. If it is not all the way back, push on the ice bucket and depress the **ICE** key pad on the glasswell at the same time.
- To ensure that the ice bucket is properly positioned, check to make sure that the freezer utility rack has been properly installed. See Freezer Utility Rack, page 16.
- Press the **ICE** key pad on the glasswell. If you do not hear auger motor noise, wait five minutes, then try again. If you do not hear auger noise after the second try, call your Sub-Zero authorized service center.
- If the ice dispenser is not used for a long period, the ice may fuse together. To avoid this, empty the ice bucket as needed.

For extended vacations, shut off power to the unit. Empty the unit and block the doors open slightly. A 1" (25 mm) space will let fresh air in to keep the interior dry and fresh smelling.

For short vacations, remove all perishable items. Shut off the ice maker and empty the ice bucket. Do not change the control settings.

If the unit is put into service temporarily and later shut off, block the doors open to allow fresh air to circulate inside the unit. Be sure to shut off power to the unit.

If your religious observances (Sabbath Mode) require turning off the lights and ice maker, refer to Sabbath Mode, page 13.

⚠ CAUTION

Be sure to block doors open when unit is not in service. Moisture buildup during even the shortest amount of running time could attack the metal.



OPERATIONS

DOOR AND DRAWER CLOSING

Models 611, 611G, 650 and 650G: Your refrigerator door has a door closing cam to help in closing the door. With the door opened to about 120 degrees, the cam will hold in the open position if the door is stopped. As you close the door, the cam will take over at about 15 degrees to help close the door.

Your freezer drawer has a self-closing mechanism. The incline, built into roller assemblies on the drawer, uses gravity to assist in closing the drawer.

If your Built-In unit is positioned in a corner, you may want to install an optional door stop kit, which limits door opening to 90 degrees. This door stop is provided with each Model 611, 611G, 650 and 650G and is shipped in a plastic bag in the grille area.

DOOR CLOSING

Models 601R, 601RG, 601F, 661, 642, 685, 632 and 695: Your refrigerator and freezer doors have spring-loaded closure mechanisms. As the doors are closed, the door closure engages to help close and seal the doors. An optional 90-degree or 105-degree door stop is available through your Sub-Zero dealer.

ACCESSORIES

Optional accessories are available through your Sub-Zero dealer. To obtain local dealer information, visit the Locator section of our website, subzero.com.

CONDENSER FAN MOTOR

All Built-In models have a fan behind the grille to cool the compressor area. This fan runs with either compressor.

AUTOMATIC DEFROST

Your Sub-Zero unit is equipped with an automatic defrost system. The refrigerator section will defrost during each off cycle of the refrigerator compressor. The freezer section is controlled by an energy-saving Adaptive Defrost system, which defrosts as needed.

SOUNDS

You may hear some noises in the normal operation of the unit. Surrounding acoustics like walls, floors and cabinets may affect the sound of your unit. For example, a gurgling or running water sound is probably refrigerant circulating through the tubing. In Models 685 and 695, the ice dispenser valve inside the refrigerator door snaps closed five seconds after either the **ICE** or **WATER** key pad is released.

During the ice maker cycle you may hear the sound of ice dropping into the container or the solenoid valve operating while refilling the ice maker with water. During the freezer defrost you may hear crackling and/or sizzling as the heat from the defrost element clears the frost from the freezer coil and water runs into the water pan.

While the compressors are in operation, you may hear a slight hum. During the start-up and shutdown of the compressor, you may feel vibration for a few seconds.

Some of these noises may be enhanced when the unit door(s) are open.



CLEANING

STAINLESS STEEL EXTERIOR

Classic and platinum stainless steel

finishes: To clean the exterior of the classic and platinum stainless steel finishes, use a soft, nonabrasive stainless steel cleaner like Signature Polish and apply with a soft 100% lint-free cloth.

Signature Polish is available from Signature Limited Laboratory, P. O. Box 13436, Dayton, Ohio 45413-0436, or 877-376-5474 (toll free).

Carbon stainless steel finish: Carbon stainless steel can be cleaned with mild soap and water.

The carbon stainless steel finish uses the interest of brushed steel to bring out the maximum metallic luster of its charcoal background.

Different light types and source locations can result in variations in shading on different components and areas of large appliances. These variations are normal with the carbon finish and add to the unique character of colored stainless steel.

To bring out the natural luster of all three finishes, lightly wipe the surface with a water-dampened microfiber cloth followed by a dry polishing chamois. All work should follow the grain direction of the finish. Better results are obtained by keeping the cloth in continuous contact with the stainless steel.

⚠ CAUTION

Under no circumstances should you use a metallic or highly abrasive cleaner or cloth, as this will remove the carbon finish or scratch the classic or platinum finishes.

INTERIOR CLEANING

To clean interior surfaces and removable parts, wash with a mild solution of soap and luke-warm water with a little baking soda. Do not use vinegar. Rinse and dry thoroughly. Avoid getting water on lights, Control Center and display panel.

⚠ CAUTION

Do not submerge or pour hot water over cold glass shelves.

GLASSWELL CLEANING

To clean the glasswell of Models 685 and 695, use a mild solution of soap and water with a little baking soda. Wipe up spills after removing the dispenser water grille.

For the stainless steel areas of the glasswell on Models 685 and 695, you may use the Stainless Steel Exterior cleaning procedure.

SIGNATURE POLISH

Signature Polish is available from Signature Limited Laboratory, P. O. Box 13436, Dayton, Ohio 45413-0436, or call 877-376-5474 (toll free).



CLEANING

CONDENSER CLEANING

In all Built-In models, the condenser is located behind the grille. First, remove the grille. Then using a soft bristle brush, vacuum to remove dust and lint from the condenser. NOTE: To avoid bending the condenser fins, be sure to vacuum in the direction of the fins (up and down). Clean the condenser area every three to six months.

⚠ CAUTION

Before cleaning the unit, shut the electricity off at the control panel. When you clean the condenser, wear gloves to avoid injury from the sharp condenser fins.

⚠ CAUTION

Failure to clean the condenser could result in temperature loss or mechanical failure or damage.

GRILLE REMOVAL

Framed and stainless steel louvered grilles:

First remove the grille screws located at the bottom of the grille. NOTE: Grille screws are accessed with door(s) open. Tilt the grille forward at the top and release the springs from behind the grille, then lift it off. Refer to the illustration below.

Overlay panel grille: To remove, lift up, then pull out at the bottom and down to release from its mounting bracket. Refer to the illustration below.

Models 601R, 601RG and 601F louvered grille: Remove the two black screws in the lowest louver in the grille. Tilt the bottom of the grille out and away. It will release from the top of the grille. Refer to the illustration below.

Model 601RG stainless steel grille: Remove in a similar fashion as the overlay panel grille.

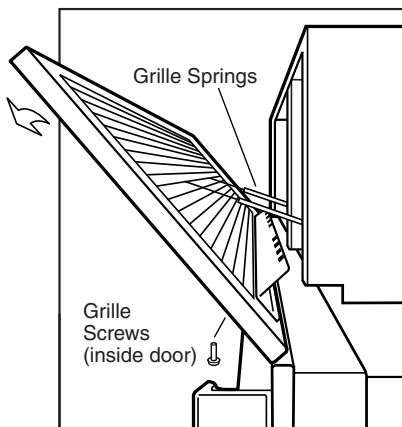

Louvered grille removal

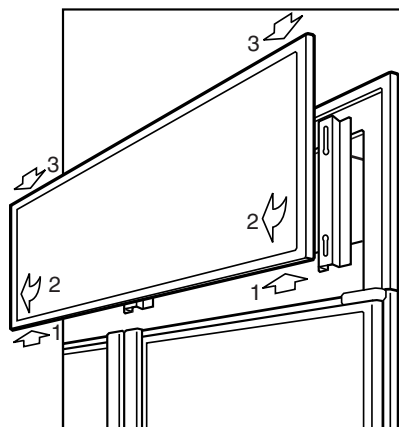

Overlay panel grille removal

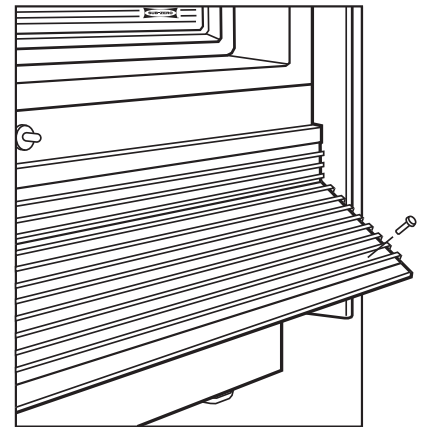

**Louvered grille removal –
Models 601R, 601RG and 601F**



CLEANING COMBINATION UNITS

For Models 611, 611G, 650, 650G, 661, 642, 632, 685 and 695, it is possible to turn off one section of your combination unit for an extended period without disrupting the other.

First, turn the unit off, then push and hold the **WARMER** key pad of the section you want to disable. Then, turn the unit back on by depressing the **UNIT ON/OFF** key pad. The disabled section will be indicated with "--" in the Control Center display panel. Repeat the process to turn the section back on. See Electronic Control System, page 12.

CLEANING THE ICE CHUTE

For Models 685 and 695, ice crescents may occasionally become lodged in the ice chute. The ice chute is a clear plastic housing that directs ice from the freezer ice bucket to the glasswell ice dispenser in the door.

To remove these obstructions, first remove the adjacent shelves, then remove the screw in the lower left corner of the side panel. Hold the bottom of the side panel and push rearward, then pull out. Once the panel is removed, the ice chute will be visible. Refer to the illustration below.

To remove the side cover of the ice chute, press the two side locking tabs, then pull up and out. To reinstall, make sure the bottom section of the ice chute is installed first. Then fit the outside front cover lip inside the stationary portion. Finally, push the two assemblies together and close the self-locking tabs.

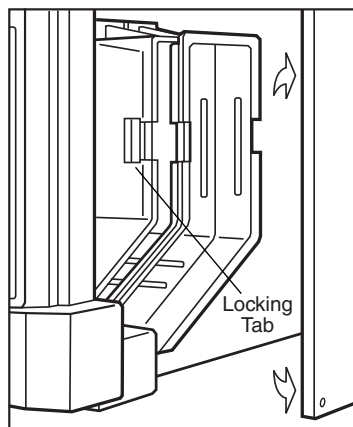

Ice chute – Models 685 and 695



LIGHTING INFORMATION

IMPORTANT NOTE: When the refrigerator or freezer doors are left open for a long time, the lights may go off. This protects the internal parts from overheating. To reset the light system, close the door for 15 to 30 minutes.

Your Sub-Zero Built-In unit contains standard 40 watt appliance bulbs (part #3030030) in refrigerator and freezer sections.

OVERHEAD LIGHTING

You'll need to remove the light shield in the top of the refrigerator or freezer to replace the bulbs. Place your hands under the light shield and release the two clips on the back of the light shield, then lift up and slide back slowly until the key slots on the side of the light shield drop past the mounting studs in the side walls. Then remove the shield. The bulbs are now accessible. Refer to the illustration below.

Models 601RG, 611G and 650G: Like all Sub-Zero units, lights in glass door models will fully illuminate when the door is open. With the 601RG, 611G and 650G, however, you have the option of having subdued lighting even with the door closed. You can easily turn this feature off by depressing the **LIGHT ON/OFF** key pad on the Control Center.

FREEZER LIGHTING

Freezer basket lighting is located below the ice maker and mounted on the back wall of the freezer. To remove the light shield, gently compress the shield to release the top, then the bottom. The bulb is now accessible. To reinstall the shield, put the bottom in place first, then compress and insert the top. Refer to the illustration below.

Models 611, 611G, 650 and 650G: Freezer lighting is in the top of the freezer, mounted to the front of the evaporator cover. The bulbs are accessible by opening the freezer drawer and unscrewing the bulb from the top front of the freezer.

Models 685 and 695: Freezer lighting is accessible above the ice bucket once the freezer utility rack has been removed. See Ice Bucket Removal, page 16.

⚠ CAUTION

Shut off power at the control panel before changing light bulbs. Wear protective gloves when handling bulbs.

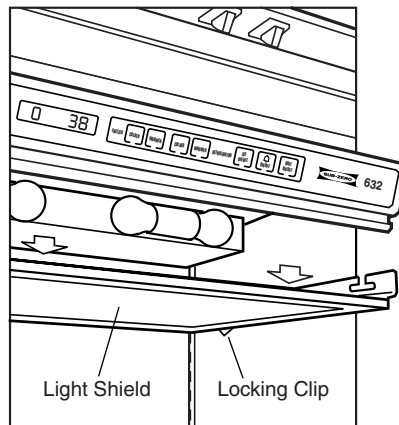

Light shield removal

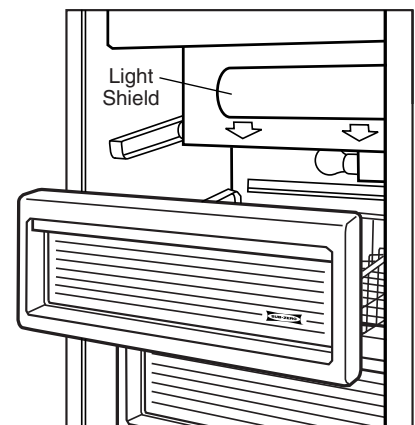

Freezer basket lighting

KEEPING **FOOD FRESH**

Your Sub-Zero unit features our unique dual compressor refrigeration system to keep food fresher longer. However, the quality and safety of your food also depends on how you handle it.

The information in this section gives you the most up-to-date handling and storage recommendations to help you keep food at its best. If you have specific questions that are not addressed here, contact your University or County Extension Service or your local utility company.

Most food inevitably deteriorates over time. From the very beginning until it is consumed, food undergoes changes. Microorganisms get into food, multiply and cause spoiling.

Enzymes that occur naturally in food continue the ripening process even after the food is harvested. Improper temperatures cause food to deteriorate faster. Changes in humidity cause wilting and shriveling that can lead to spoiling.

Sub-Zero's exclusive dual refrigeration system is specifically designed to combat these changes and keep your food fresh longer. The individual refrigerator and freezer systems have been designed to maintain accurate, consistent temperatures and proper humidity levels for longer food life expectancy. Dual refrigeration eliminates transfer of fresh food odors to frozen food or ice and does not freeze the moisture out of the air in the fresh food section.

In addition, good handling practices can minimize the rate of changes in food.

HANDLING RECOMMENDATIONS

- Follow the recommended storage times and temperatures in this guide. Your Sub-Zero unit helps to slow the ripening process by tailoring temperatures to each section as needed.
- Use specially designed compartments for dairy foods, deli foods and fresh produce. These compartments maintain temperature and humidity levels that keep specific food groups fresh.
- Rotate food in refrigeration units, using a first-in, first-out system.
- When food does spoil, it's usually obvious. It becomes moldy, has an off-odor, looks rotten or discolored. But there are times when spoiling may not be so apparent. If you think a food has been stored too long, discard it. Don't taste it to check if it's okay.
- While the bacteria that cause food spoilage will not cause food borne illness or food poisoning, taste tests are not a good idea.



KEEPING FOOD AT ITS BEST

KEEPING FOOD SAFE TO EAT

Most food borne illness is caused by bacteria such as staphylococcus, salmonella, E-coli and clostridium botulinum, the bacteria that causes botulism. These bacteria grow rapidly at temperatures between 40°F (4°C) and 140°F (60°C), a range that's called the **Danger Zone**. Never leave food in the danger zone for more than two hours. When the bacteria have multiplied to the millions in warm temperatures, they cause illness. Some bacteria cause flu-like symptoms, while others cause serious illness or even death. Young children, the elderly and people who are already ill are more likely to become sick from food poisoning.

To reduce your risk of food borne illness, use the following techniques to keep your food safe to eat:

WHEN YOU'RE SHOPPING

- Place packages of raw meat, seafood or poultry in plastic bags to keep them from dripping on other foods.
- Shop for meat, seafood and poultry last. Don't leave these foods in a hot car when you've finished shopping. Take along a cooler in hot weather or when you have to travel long distances.
- Check **use by** and **sell by** dates on foods to make sure they're fresh. Use extra care when buying deli food. Buy only the amount you will use in 1–2 days. Discard hot or cold deli food that has been at room temperature for more than two hours.

WHEN YOU STORE FOOD

- Monitor temperatures of the refrigerator and freezer sections on the electronic control panel of your Sub-Zero unit. Keep the refrigerator temperature at 40°F (4°C) or below and freezer temperature at 0°F (-18°C).
- Follow the recommended refrigerator and freezer storage times and temperatures in this guide.
- Store raw meat, poultry and seafood separate from other foods. Keep juices from these packages from dripping on other food.
- Never taste food that looks or smells strange to test its freshness. Discard it.
- For refrigerator storage, leave raw meat, poultry and seafood in its original wrapper unless it is torn. Repeated handling can introduce bacteria to these foods.
- Wrap food stored in the refrigerator unit in foil or plastic wrap, or place it in plastic bags or airtight containers to keep it from drying out. Date all packages.
- For freezer storage, use freezer wrap, freezer-quality plastic bags or aluminum foil over the commercial wrap if foods will be stored in the freezer for more than a couple of months. This minimizes dehydration and quality loss. Single layers of aluminum foil may tear and cause freezer burn.



WHEN YOU PREPARE FOOD

- Clean everything that comes in contact with food.
- Wash your hands for 20 seconds before and after handling food.
- Sanitize counters, equipment and utensils after handling raw meat, seafood or poultry. Rinse with a dilute chlorine bleach solution, one teaspoon to a quart of water.
- Use clean kitchen towels, sponges and cloths. Replace sponges every few weeks.
- Use disposable plastic gloves if you have an infected cut or burn on your hands.
- Thaw food in the refrigerator or microwave oven, not on the counter. When you thaw food in a microwave oven, cook it immediately.
- Marinate food only in the refrigerator.
- Rinse poultry and seafood in cold water before cooking.
- Avoid cross-contamination in preparing food. Keep raw meat, poultry and seafood and their juices away from other food. For example, don't use the same surface and utensils for preparing raw meat, poultry and seafood that you use for preparing salad ingredients.
- Thoroughly clean your plastic and wooden cutting boards. Wash with hot water and soap and rinse with a diluted chlorine bleach solution of one teaspoon to a quart of water.

WHEN YOU COOK FOOD

- Cook meat to an internal temperature of 165°F (74°C) or above, poultry to 180°F (82°C) or above. For cuts more than 2" (51 mm) thick, use a meat thermometer to check the temperature. For thinner cuts, clear juices (not pink) are a sign of doneness.
- If you are cooking frozen meat or poultry that has not been defrosted, increase the cooking time to 1½ times the time required for thawed items.
- Roast meats or poultry in oven temperatures of 325°F (163°C) or above.
- Cook eggs until the yolk and white are firm, not runny.
- Don't use recipes in which eggs remain raw or partially cooked.
- If your microwave has a temperature probe, use it. Check temperatures of meat and poultry in at least three spots. Rotate foods during microwaving.
- Don't taste raw or partially cooked meat, poultry, eggs or fish.

WHEN YOU HAVE LEFTOVERS

- Refrigerate or freeze cooked leftovers in small, covered containers within 2 hours after cooking. Make sure there is adequate air space around the containers so that food can cool down quickly.
- Remove the stuffing from meat or poultry and store it separately.
- Date packages of leftovers and use within a safe period of time.
- Cover and reheat leftovers thoroughly before serving.
- Bring sauces, soups and gravy to a boil. Heat other foods to 165°F (74°C).
- If you think food may be spoiled, discard it. When in doubt, throw it out.



FRESH FOOD STORAGE

Shelf life of fresh foods varies depending on how fresh it is when you buy it. To keep your food fresher longer, follow the recommended storage tips.

Vegetables: Wash vegetables in cool water and drain. Store in airtight containers or plastic wrap. Vegetables stay fresh longer in high humidity storage.

Fruits: Wash and dry fresh fruits. Store more aromatic fruits in plastic bags. Most fruits stay fresh longer in low humidity storage.

Prepackaged Meats: Store in original packaging. After opening, rewrap tightly in plastic wrap or aluminum foil.

Fresh Meats, Fish and Poultry: Remove store wrappings, then rewrap in plastic wrap, foil or waxed paper and refrigerate immediately.

Eggs: Store eggs unwashed in their carton or a portable egg tray. Use within 2 weeks.

Milk, Cream and Cottage Cheese: Keep carton closed. Store on refrigerator shelf and use within 5 days.

Cheese: Store in original packaging until ready to use. After opening, rewrap tightly in plastic wrap or aluminum foil.

Leftovers: Let cool and cover tightly with plastic wrap or foil. Airtight plastic containers work well to prevent drying out and odor transfer.

FROZEN FOOD STORAGE

Freezer Storage: Wrap foods in material designed for frozen food storage. The wrap must seal out air and moisture. **Do not refreeze thawed meats.**

Ice Cream: The firmness of the ice cream will depend on its cream content. Higher quality ice creams usually have a higher cream content, requiring colder freezer temperatures to maintain their firmness. Soft ice cream is not always an indication of a temperature problem.

Make sure your refrigerator and freezer doors close freely and completely. Overloading will affect temperatures inside the unit. Do not fill your freezer with large quantities of unfrozen foods expecting them to fast freeze. Give the freezer ample time to circulate cold air around unfrozen items before adding additional items.

SUGGESTED **FOOD STORAGE**

The food storage charts on the following pages give you specific information to help you keep food safe and keep it at its best quality. The recommended storage temperatures will help you determine optimal storage conditions for your food. As a general rule, food that is handled properly and kept at temperatures below 40°F (4°C) will be safe to eat.

Storing food at temperatures below 40°F (4°C) keeps it out of the **Danger Zone**. The storage times for refrigeration will help keep food from spoiling or becoming dangerous to eat. The time limits for frozen foods are to maintain flavor and texture. Food kept frozen longer than the recommended time will still be safe to eat, but its quality may diminish.



FISH, MEATS AND POULTRY

	Recommended Temperature	Storage Life (refrigerator)	Storage Life (freezer)*	Comments
FRESH FISH & SEAFOOD				
cod, flounder, haddock	32°F (0°C)	2 days	6 months	Freeze in original wrap up to 2 weeks. Use freezer wrap, freezer-quality plastic bags or aluminum foil over the commercial wrap if foods will be frozen for more than a couple of months.
sole bluefish, perch	32°F (0°C)	2 days	2–3 months	
mackerel, salmon	32°F (0°C)	4 days	5–9 months	
shrimp, oysters	32°F (0°C)	1 day	6 months	
FRESH MEAT				
beef steaks, roasts	32–35°F (0–2°C)	3–5 days	6–12 months	Freeze in original wrap up to 2 weeks. Use freezer wrap, freezer-quality plastic bags or aluminum foil over the commercial wrap if foods will be frozen for more than a couple of months.
lamb chops, roasts	32–35°F (0–2°C)	3–5 days	6–9 months	
pork and veal chops, roasts	32–35°F (0–2°C)	3–5 days	4–6 months	
variety meats (tongue, liver, etc.)	32–35°F (0–2°C)	1–2 days	3–4 months	
HAMBURGER, GROUND & STEW MEATS				
hamburger, stew meats, ground turkey, veal, pork, lamb and mixtures	32–35°F (0–2°C)	1–2 days	3–4 months	Freeze in original wrap up to 2 weeks. Use freezer wrap, freezer-quality plastic bags or aluminum foil over the commercial wrap if foods will be frozen for more than a couple of months.
HOTDOGS & LUNCH MEATS				
hotdogs (opened package)	32–35°F (0–2°C)	1 week	1–2 months	Freeze in freezer wrap. Check “sell by” dates. Do not use more than 1 week after this date.
hotdogs (unopened package)	32–35°F (0–2°C)	2 weeks	1–2 months	
lunch meats (opened package)	32–35°F (0–2°C)	3–5 days	1–2 months	
lunch meats (unopened package)	32–35°F (0–2°C)	2 weeks	1–2 months	
BACON & SAUSAGE				
bacon	32–35°F (0–2°C)	7 days	1 month	Keep wrapped, and store at recommended refrigerator temperatures.
raw sausage (pork, beef, turkey)	32–35°F (0–2°C)	1–2 days	1–2 months	
smoked breakfast links or patties	32–35°F (0–2°C)	7 days	1–2 months	
hard sausage (pepperoni, jerky sticks)	32–35°F (0–2°C)	2–3 weeks	1–2 months	
HAM & CORNED BEEF				
corned beef	32–35°F (0–2°C)	5–7 days	1 month	For freezer storage, drain juices.
ham, whole	32–35°F (0–2°C)	7 days	1–2 months	
ham, half	32–35°F (0–2°C)	3–5 days	1–2 months	
ham, slices	32–35°F (0–2°C)	3–4 days	1–2 months	
FRESH POULTRY				
chicken or turkey, whole	32–35°F (0–2°C)	1–2 days	12 months	Freeze in original wrap up to 2 weeks. Use freezer wrap, freezer-quality plastic bags or aluminum foil over the commercial wrap if foods will be frozen for more than a couple of months.
chicken or turkey, pieces	32–35°F (0–2°C)	1–2 days	9 months	
duck or goose	32–35°F (0–2°C)	1–2 days	6 months	

*Recommended freezer storage temperature is 0°F (-18°C).



FOOD STORAGE RECOMMENDATIONS

FRESH VEGETABLES

	Recommended Temperature	Storage Life (refrigerator)	Comments	
FRESH VEGETABLES				
anise	34–36°F (1–2°C)	2–3 weeks	Wash vegetables in cool water and drain. Store in airtight container or plastic wrap.	
artichokes	34°F (1°C)	1–2 weeks		
asparagus	34–36°F (1–2°C)	2–3 weeks		
beans, green/snap/lima*	40–45°F (4–7°C)	10–14 days		
bean sprouts	34°F (1°C)	7–9 days		
beets	34°F (1°C)	3–5 months		
belgian endive	36–38°F (2–3°C)	2–4 weeks		
bok choy	34°F (1°C)	3 weeks		
broccoli	34°F (1°C)	1–2 weeks	Most vegetables should be stored in higher humidity. Discard any fresh vegetables that are moldy or have other signs of spoilage and wipe out the refrigerator compartment. For fresh-cut produce, follow storage directions on package.	
brussels sprouts	34°F (1°C)	3–5 weeks		
cabbage	34°F (1°C)	3–6 months		
carrots	34°F (1°C)	1–5 months		
cauliflower	34°F (1°C)	3–4 weeks		
celeriac	34°F (1°C)	6–8 months		
celery	34°F (1°C)	2–4 weeks		
chinese broccoli	34°F (1°C)	10–14 days		
chinese cabbage	34°F (1°C)	2–3 months		Refer to the list of ethylene sensitive and ethylene producing vegetables and fruits.
corn, sweet	34°F (1°C)	4–6 days		
cucumbers*	45–50°F (7–10°C)	1–2 weeks		
daikon	34°F (1°C)	4 months		
eggplant*	45–50°F (7–10°C)	1–2 weeks		
endive/escarole	34°F (1°C)	2–3 weeks		
garlic	34°F (1°C)	3–6 months		
ginger root*	55°F (13°C)	6 months		
horseradish	34°F (1°C)	10–12 months		
jerusalem artichokes	34°F (1°C)	1–2 weeks		
jicama*	55–65°F (13–18°C)	4–5 months		
kale	34°F (1°C)	1–2 months		
kohlrabi	34°F (1°C)	10–14 days		
leeks	34°F (1°C)	2–3 months		
lettuce	34°F (1°C)	2–3 weeks		
mushrooms	34°F (1°C)	2–3 weeks		
okra*	45–50°F (7–10°C)	1–2 weeks		
onions, bulb	34°F (1°C)	1–6 months		
onions, green	34°F (1°C)	7–10 days		
parsley	34°F (1°C)	1–2 months		
parsnips	34°F (1°C)	4–5 months		
peas, pods and shelled	34°F (1°C)	7–10 days		
peppers, bell*	45–50°F (7–10°C)	12–18 days		
peppers, chile	45–50°F (7–10°C)	2–3 weeks		

*Sensitive to chill injury, a cause of spoilage. Damage may not be apparent until the vegetable is returned to a warmer temperature.

NOTE: See food preservation guide for complete instructions on freezing vegetables. Recommended freezer storage temperature is 0°F (-18°C).



FRESH VEGETABLES

	Recommended Temperature	Storage Life (refrigerator)	Comments
FRESH VEGETABLES			
potatoes	45–50°F (4–10°C)	2–4 months	Wash vegetables in cool water and drain. Store in airtight container or plastic wrap.
pumpkins*	38–55°F (3–13°C)	3–4 months	
radicchio	34°F (1°C)	2–3 weeks	
radishes	34°F (1°C)	3–4 weeks	
romaine	34°F (1°C)	2–3 weeks	
rutabagas	34°F (1°C)	4–6 months	
salsify	34°F (1°C)	2–4 months	
shallots	34°F (1°C)	6 months	
snow peas	34°F (1°C)	1–2 weeks	Most vegetables should be stored in higher humidity. Discard any fresh vegetables that are moldy or have other signs of spoilage and wipe out the refrigerator compartment. For fresh-cut produce, follow storage directions on package.
spinach	34°F (1°C)	1–2 weeks	
squash, summer*	40–50°F (4–10°C)	1–2 weeks	
squash, winter	50–55°F (10–13°C)	3–5 months	
sweet potatoes*	55–60°F (13–16°C)	4–7 months	
tamarillos	37–40°F (3–4°C)	2 months	
tomatoes (ripe)	34–40°F (1–4°C)	3–4 weeks	
turnips	34°F (1°C)	4–5 months	
water chestnuts	34–36°F (1–2°C)	1–2 months	Refer to the list of ethylene sensitive and ethylene producing vegetables and fruits.
watercress	34°F (1°C)	2–3 weeks	

*Sensitive to chill injury, a cause of spoilage. Damage may not be apparent until the vegetable is returned to a warmer temperature.

NOTE: See food preservation guide for complete instructions on freezing vegetables. Recommended freezer storage temperature is 0°F (-18°C).



FRESH FRUITS

	Recommended Temperature	Storage Life (refrigerator)	Comments
FRESH FRUITS			
apples	34–40°F (1–4°C)	3–6 months	Wash and dry most fruits, and store in the crisper compartment. (Do not wash berries and cherries until you are ready to use them, however.)
apricots	34°F (1°C)	1–2 weeks	
asian pears	34°F (1°C)	5–6 months	
avocados*	40°F (4°C)	2–4 weeks	
blackberries	34°F (1°C)	2–3 days	
blood oranges	40–44°F (4–7°C)	3–8 weeks	
blueberries	34°F (1°C)	10–18 days	
cantaloupe*	36–40°F (2–4°C)	10–14 days	
<hr/>			
cassavas	34°F (1°C)	1–2 months	Most fruits should be stored in lower humidity.
cherries, sweet	34°F (1°C)	2–4 weeks	
clementines	40°F (4°C)	2–4 weeks	Fully ripe fruits should be stored in the refrigerator at recommended temperatures to slow down the ripening process.
cranberries*	36–40°F (2–4°C)	2–4 months	
figs, fresh	34°F (1°C)	7–10 days	Unripe fruits should be left to ripen at room temperature, in a container that allows for air circulation.
grapefruit*	50–60°F (10–16°C)	4–6 weeks	
grapes	34°F (1°C)	8–12 days	
guavas*	40–50°F (4–10°C)	2–3 weeks	
<hr/>			
honeydew	45–50°F (7–10°C)	3–4 weeks	To hasten the ripening process, you can place unripe fruit in a paper bag that has holes poked in it. Close the bag and set it on a counter. The fruit will produce ethylene, a gas that initiates the ripening process. Check the bag each day.
kiwifruit	34°F (1°C)	4–6 weeks	
kumquats	40°F (4°C)	2–4 weeks	
lemons*	50–55°F (10–13°C)	1–5 months	
limes*	48–50°F (9–10°C)	3–5 weeks	
lychees	35°F (2°C)	3–5 weeks	
mangoes*	50°F (10°C)	2–3 weeks	
nectarines	34°F (1°C)	2–4 weeks	
<hr/>			
oranges*	34–48°F (1–9°C)	3–8 weeks	Refer to the list of ethylene sensitive and ethylene producing vegetables and fruits.
papayas*	45–55°F (7–13°C)	1–3 weeks	
peaches	34°F (1°C)	2–4 weeks	
pears	34°F (1°C)	2–3 weeks	
persimmons	34°F (1°C)	3–4 months	
pineapple*	45°F (7°C)	2–5 weeks	
plums and prunes	34°F (1°C)	2–4 weeks	
pomegranates*	40°F (4°C)	2–3 months	
<hr/>			
quinces	34°F (1°C)	2–3 months	
raspberries	34°F (1°C)	2–3 days	
rhubarb	34°F (1°C)	2–3 weeks	
strawberries	34°F (1°C)	5–10 days	
tangerines	40°F (4°C)	2–4 weeks	
watermelon*	45–55°F (7–13°C)	2–3 weeks	

*Sensitive to chill injury, a cause of spoilage. Damage may not be apparent until the fruit is returned to a warmer temperature.

NOTE: See food preservation guide for complete instructions on freezing fruits. Recommended freezer storage temperature is 0°F (-18°C).



DELI FOODS, DAIRY PRODUCTS AND OTHER FOODS

	Recommended Temperature	Storage Life (refrigerator)	Storage Life (freezer)*	Comments
DELI FOODS				
thinly sliced lunch meats	32–35°F (0–2°C)	1–2 days	NR	Check “use by” or “sell by” dates. These foods do not freeze well. If you need to freeze, do so immediately, not after they have been held in the refrigerator.
egg, chicken, tuna and ham salads	32–35°F (0–2°C)	3–5 days	NR	
macaroni salads	32–35°F (0–2°C)	3–5 days	NR	
pre-stuffed chops, chicken breasts	32–35°F (0–2°C)	1 day	NR	
store-prepared convenience meals	32–35°F (0–2°C)	1–2 days	NR	
DAIRY FOODS				
butter	32–35°F (0–2°C)	3 months	1 year	Check “sell by” dates.
cottage or ricotta cheese	32–35°F (0–2°C)	1–2 weeks	4 weeks	
cream cheese	32–35°F (0–2°C)	2 weeks		Store cheese in original packaging until ready to use. After opening, rewrap tightly in plastic wrap or aluminum foil.
natural cheese (cheddar, brick, etc.)	32–35°F (0–2°C)	3–6 months	6–8 months	
process cheese	32–35°F (0–2°C)	3–4 weeks	6–8 months	
grated Parmesan or Romano	32–35°F (0–2°C)	1 year		
yogurt	32–35°F (0–2°C)	1 month		Thaw frozen cheese in the refrigerator to reduce crumbling.
whole, lowfat or skim milk	32–35°F (0–2°C)	1–2 weeks		
EGGS				
fresh, in shell	32°F (0°C)	3 weeks	NR	Keep fresh eggs refrigerated.
hard cooked	32–35°F (0–2°C)	1 week	NR	
liquid pasteurized or egg substitutes				Do not eat hard cooked eggs that have been at room temperature for more than 2 hours.
opened	32–35°F (0–2°C)	3 days	NR	
unopened	32–35°F (0–2°C)	10 days	1 year	
COOKED MEAT & POULTRY LEFTOVERS				
cooked meat and meat dishes	32–35°F (0–2°C)	3–4 days	2–3 months	Refrigerate or freeze leftovers in covered shallow containers within 2 hours after cooking. Reheat leftovers to 165°F (74°C).
gravy and meat broth	32–35°F (0–2°C)	1–2 days	2–3 months	
fried or plain chicken, pieces	32–35°F (0–2°C)	3–4 days	4 months	
cooked poultry dishes	32–35°F (0–2°C)	3–4 days	4–6 months	
pieces covered with broth, gravy	32–35°F (0–2°C)	1–2 days	6 months	
chicken nuggets, patties	32–35°F (0–2°C)	1–2 days	1–3 months	
SOUPS & STEWS				
vegetable	32–35°F (0–2°C)	3–4 days	2–3 months	Reheat to at least 165°F (74°C) before serving.
meat added	32–35°F (0–2°C)	3–4 days	2–3 months	

*Recommended freezer storage temperature is 0°F (-18°C). (NR) stands for not recommended for freezing.



ETHYLENE

Some fruits and vegetables will produce ethylene, a gas that initiates the ripening process. Ethylene can cause premature ripening in some foods, while in others, it can actually cause damage.

To reduce unnecessary spoilage of your produce, do not store ethylene producing fruits and vegetables with those that are sensitive to it. Refer to the following lists.

ETHYLENE PRODUCING FOODS

apples	mangosteen
apricots	nectarines
avocados	papayas
ripening bananas	passion fruit
cantaloupe	peaches
cherimoyas	pears
figs	persimmons
guavas	plantains
honeydew	plums
kiwifruit	prunes
mamey sapote	quince
mangoes	tomatoes

ETHYLENE SENSITIVE FOODS

unripe bananas	leafy greens
green beans	lettuce
belgian endive	okra
broccoli	parsley
brussels sprouts	peas
cabbage	peppers
carrots	spinach
cauliflower	squash
chard	sweet potatoes
cucumbers	watercress
eggplant	watermelon
unripe kiwifruit	

NOTE: Do not store ethylene producing foods with ethylene sensitive foods.



TROUBLESHOOTING

If your refrigerator or freezer is not operating properly, use the following troubleshooting guide before calling your Sub-Zero authorized service center. This guide will save you time and trouble and may help you avoid the expense of a service call.

SERVICE is illuminated in the Control Center display panel

- The microprocessor has sensed a problem with the operating system. There may be instructions in the Control Center display panel to solve the problem. If not, call the Sub-Zero Customer Service Department at 800-222-7820.

SERVICE is flashing in the Control Center display panel

- This may indicate that the condenser needs cleaning. Follow the Condenser Cleaning procedure outlined on page 22.
- This happens when one or more of the sections runs too long. A temperature sensor may be faulty. If this occurs, turn the unit off with the **UNIT ON/OFF** key pad and then restart by depressing the key pad again. If SERVICE is still flashing, call the Sub-Zero Customer Service Department at 800-222-7820.

SERVICE and ICE are both flashing in the Control Center display panel

- This occurs when the solenoid valve for the ice maker is activated too long. Check for excess water near the ice maker. If you see excess water, turn off the water at the shut-off valve and call for service. If there is no excess water, turn the unit off and back on to reset and see if this corrects the problem. If the problem continues, call the Sub-Zero Customer Service Department at 800-222-7820.

Refrigerator/Freezer is not running

- Is there electrical power to the unit?
- Is the home circuit breaker or fuse off?
- Is the refrigerator/freezer control on?
- Is the condenser area clean?
- Has a door or drawer been left open for an extended period? Be sure that food is not obstructing proper door or drawer closing.
- If the unit is still not running, it may be in defrost mode.
- Wait 30 minutes and try to restart again.

Refrigerator/Freezer is warmer than usual

- Is the control set properly?
- Is the condenser area clean?
- Has a door or drawer been left open for an extended period? Be sure that food is not obstructing proper door or drawer closing.
- Has a large amount of food been added recently?

Refrigerator/Freezer runs for long periods of time

- Is the condenser area clean?
- Has a door or drawer been left open for an extended period? Be sure that food is not obstructing proper door or drawer closing.
- Has a large amount of food been added recently?
- On hot days and in warm room temperatures, the motor runs longer.
- There may be normal operation noises related to refrigerant circulation, fan operation, ice maker operation, defrost cycle or compressor operation.



TROUBLESHOOTING

Refrigerator/Freezer is frosted up

- Has a door or drawer been left open for an extended period? Be sure that food is not obstructing proper door or drawer closing.
- Are door(s) and/or drawer closing and sealing properly? Contact your dealer if door(s) are not adjusted properly. NOTE: When opening the freezer drawer, you may notice a side-to-side motion in the drawer. This motion is normal, with the tolerance built into the drawer slides. When the drawer is closed it will automatically adjust and close with correct alignment.

You hear unusual noises

- These noises may be normal operating sounds related to refrigerant circulation, fan operation, ice maker operation, defrost cycle or compressor operation. Noises may be more noticeable when door(s) are open.

You hear occasional buzzing

- Is the water supply connected to ice maker and turned on?

Condensation forms inside the unit

- This is normal during periods of higher humidity (summer) and with frequent door openings.
- Are door(s) and/or drawer closing and sealing properly?

Condensation forms outside the unit

- During periods of high humidity, some condensation may appear on outside surfaces. The condensation will disappear when the humidity drops. Be sure that door(s) and/or drawer are closing and sealing properly. If condensation persists, contact your Sub-Zero authorized service center.

Outside of the freezer section heats up

- Clean the condenser area.

There is no ice

- Is the ice bucket in position?
- Is the ice maker turned on?
- Is SERVICE ICE flashing in the Control Center display panel? See Visual Service Display, page 13.
- Is the water supply connected?

There is an odor inside the unit

- Clean the unit thoroughly.
- Cover all food tightly.
- Clean the unit drain pipe.
- Clean the drain pan.

Light bulb needs to be replaced

- See Lighting Information, page 24.

⚠ WARNING

Shut off power to the unit at the circuit breaker before replacing light bulbs. Wear protective gloves when handling bulbs.

You need product information

- Call the Sub-Zero Customer Service Department at 800-222-7820 or visit our website, subzero.com, for planning, installation and product information.

You need service

- Check the model and serial number of your unit on the plate located at the top of the side frame, inside the unit, close to the hinge. Call your Sub-Zero authorized service center, contact your dealer or the Sub-Zero Customer Service Department, P. O. Box 44130, Madison, WI 53744-4130, 800-222-7820. You may also check the service center locator on our website, subzero.com.



FREQUENTLY ASKED QUESTIONS

ICE PRODUCTION

IMPORTANT NOTE: Make sure that the power is on for your ice maker. ICE will be visible in the Control Center display panel.

IMPORTANT NOTE: Dispose of the first bucket of ice produced by your new unit to ensure that pipe residue or other particles associated with new water lines are not consumed.

Q: My ice maker isn't producing very much ice.

A: On average, you can expect a cycle of ice (eight cubes per cycle) every two hours.

Q: My ice is freezing together and clumping.

A: If ice is not used regularly it tends to fuse together. You may need to discard the ice and allow ice to be replenished.

Q: My ice tastes funny and is discolored.

A: Sub-Zero Built-In units do not have an integrated water filtration system. Contact a local plumber to discuss water filtration options.

NOISE

Q: Why do I hear my unit running constantly?

A: It is normal to hear the operation of fans and motors. Sounds will be accentuated based on the placement of the unit and overall room design.

TEMPERATURE

IMPORTANT NOTE: Unless the unit is being serviced, make sure the power for your unit is on. If the unit is not on, OFF will be visible in the Control Center display panel.

Q: How do I adjust the temperatures?

A: To adjust temperatures, refer to Temperature Control, page 12.

Q: What are the suggested temperature settings?

A: The recommended settings are 38°F (3°C) for the refrigerator section and 0°F (-18°C) for the freezer section.

Q: Condensation is forming on the inside and outside of my unit.

A: In climates with higher humidity, condensation will form and is considered normal. Leaving the door open for a long period of time may also contribute to condensation forming on the inside your unit.

Q: My unit isn't cooling properly.

A: Clean the condenser area as outlined on page 22.

DOOR OPERATION

Q: Why is my door hard to open?

A: Your unit was designed for an airtight seal. A vacuum seal can form after the door is closed. Wait several seconds for pressure to equalize before reopening the door.

Q: The door on my unit is opening too fast and hitting the wall or surrounding cabinets.

A: The unit may not be leveled properly or a door stop may be required. Contact your Sub-Zero dealer for details on the door stop kit.



SERVICE INFORMATION

SERVICE INFORMATION

This Use & Care Information book gives you the tools necessary to preserve food at optimum quality in your Built-In unit. Keep doors and drawers closed as much as possible whenever the unit is operating.

If you do need service, be sure to have the model and serial number when you call. You'll find these numbers on the model and serial number plate located at the top of the side frame, inside the unit, close to the hinge. For warranty purposes, you will also need the date of installation and the name of your Sub-Zero dealer. Record this information below for future reference.

Model Number _____

Serial Number _____

Installation Date _____

Sub-Zero Authorized Service Center and Phone

Sub-Zero Dealer and Phone

BEFORE CALLING FOR SERVICE

Before calling a Sub-Zero authorized service center, refer to the Troubleshooting Guide on pages 35–37. Check the household fuse or circuit breaker to see if it has been blown or tripped and that the electrical connection to the appliance has not been disconnected. A power outage may also have caused a disruption in service.

PRODUCT REGISTRATION

Register your new Sub-Zero today so that we may ensure your satisfaction. You may register by one of the following options:

- 1) Mail in the completed Sub-Zero Product Registration Card.
- 2) Register online at **subzero.com**.
- 3) Register by phone by calling the Sub-Zero Customer Service Department at **800-222-7820**.

The model and serial numbers of your unit are printed on the enclosed Sub-Zero Product Registration Card. If you provide us with your e-mail address, we will send you exciting new product updates and recipes as they become available, along with information on special events.

CONTACT INFORMATION

**Sub-Zero
Customer Service:
800-222-7820**

**Website:
subzero.com**

The information and images in this guide are the copyright property of Sub-Zero Freezer Company, Inc. Neither this book nor any information or images contained herein may be copied or used in whole or in part without the express written permission of Sub-Zero Freezer Company, Inc.

©Sub-Zero Freezer Company, Inc. all rights reserved.

SUB-ZERO FREEZER COMPANY PRODUCTS LIMITED WARRANTY

RESIDENTIAL USE ONLY

FULL FIVE YEAR SEALED SYSTEM WARRANTY LIMITED SIXTH THROUGH TWELFTH YEAR WARRANTY ON THE SEALED SYSTEM FULL TWO YEAR WARRANTY ON TOTAL PRODUCT*

FULL FIVE YEAR SEALED SYSTEM WARRANTY

For five years from the date of original installation, your Sub-Zero warranty covers all parts and labor to repair or replace any components that prove to be defective in materials or workmanship in the sealed system. The sealed system consists of the compressor, condenser, evaporator, drier and all connecting tubing.

FULL TWO YEAR WARRANTY*

For two years from the date of original installation, your Sub-Zero warranty covers all parts and labor to repair or replace any part of the product, that proves to be defective in materials or workmanship.

LIMITED SIXTH THROUGH TWELFTH YEAR SEALED SYSTEM WARRANTY

From the 6th through the 12th year from the date of original installation, your Sub-Zero warranty covers all parts that prove to be defective in materials or workmanship in the sealed system (parts only). The sealed system consists of the compressor, condenser, evaporator, drier and all connecting tubing.

TERMS APPLICABLE TO EACH WARRANTY

All service provided by Sub-Zero under the above warranty must be performed by an authorized Sub-Zero service center, unless otherwise specified by Sub-Zero. Service will be provided in the home during the normal business hours. This warranty applies only to products installed for normal residential use. Details regarding a non-residential warranty are available upon request.

The warranty applies only to products installed in any one of the fifty states of the United States, the District of Columbia or the ten provinces of Canada. This warranty does not cover any parts or labor to correct any defect caused by negligence, accident or improper use, maintenance, installation, service or repair, including but not limited to improper removal and reinstallation (whether in the unit or at a remote location) of the condensing unit.

THE REMEDIES DESCRIBED ABOVE FOR EACH WARRANTY ARE THE ONLY ONES THAT SUB-ZERO WILL PROVIDE, EITHER UNDER THESE WARRANTIES OR UNDER ANY WARRANTY ARISING BY OPERATION OF LAW. SUB-ZERO WILL NOT BE RESPONSIBLE FOR ANY CONSEQUENTIAL OR INCIDENTAL DAMAGES ARISING FROM THE BREACH OF THESE WARRANTIES OR ANY OTHER WARRANTIES, WHETHER EXPRESS, IMPLIED OR STATUTORY.

Some states do not allow the exclusion or limitation of incidental or consequential damages, so the above limitation or exclusion may not apply to you. This warranty gives you specific legal rights and you may also have other legal rights, which vary from state to state.

To receive parts and/or service and the name of the Sub-Zero authorized service center nearest you, contact your Sub-Zero dealer, distributor or Sub-Zero Freezer Company, Customer Service Department, P.O. Box 44130, Madison Wisconsin, 53744-4130; check the Locator section of our website, subzero.com, or call 800-222-7820.

* Stainless Steel (classic, platinum and carbon) doors, panels, product frames and stainless interior surfaces are covered by a limited 60 day parts and labor warranty for cosmetic defects.

* Replacement water filter cartridges are not covered by the product warranty.



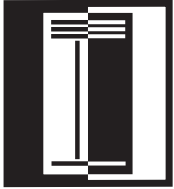

SUB-ZERO FREEZER COMPANY, INC. P. O. BOX 44130 MADISON, WI 53744-4130 800-222-7820 SUBZERO.COM

