

USE & CARE GUIDE



Multi-Function Cooktop



Contents

Wolf Multi-Function Cooktop	3
Safety Instructions	4
Multi-Function Cooktop Features	8
Multi-Function Cooktop Operation	9
Multi-Function Cooktop Care	12
Multi-Function Cooktop Recipes	15
Troubleshooting Guide	17
Service Information	18
Wolf Warranty	19

Features and specifications are subject to change at any time without notice. Visit our website, wolfappliance.com for the most up-to-date information.

IMPORTANT NOTE: Throughout this guide, dimensions in parentheses are millimeters unless otherwise specified.

Important Note

To ensure the safe and efficient use of Wolf equipment, please take note of the following types of highlighted information throughout this guide:

IMPORTANT NOTE highlights information that is especially important.

CAUTION signals a situation where minor injury or product damage may occur if instructions are not followed.

WARNING states a hazard that may cause serious injury or death if precautions are not followed.



Thank You

Your purchase of a Wolf gas multi-function cooktop attests to the importance you place upon the quality and performance of your cooking equipment. We understand this importance and have designed and built your multi-function cooktop with quality materials and workmanship to give you years of dependable service.

We know you are eager to start cooking, but before you do, please take some time to read this use & care guide. Whether you are a beginning cook or an expert chef, it will be to your benefit to familiarize yourself with the safety practices, features, operation and care recommendations of the Wolf gas multi-function cooktop.

Your Wolf multi-function cooktop is protected by a warranty that is one of the finest in the industry. Take a moment to read the warranty statement at the end of this guide and refer to it should service become necessary.

IMPORTANT NOTE: The Wolf gas multi-function cooktop is manufactured for use with natural gas or LP gas. Check the product rating plate for the type of gas for your specific model. If this appliance does not correspond to your type of gas, contact your authorized Wolf dealer.

The rating plate is located on the underside of the multi-function cooktop. Refer to the illustration below.

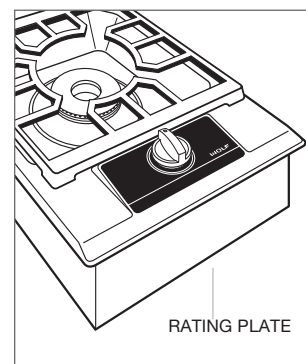

Location of rating plate.

IMPORTANT INSTRUCTIONS

▲ WARNING

If the information in this guide is not followed exactly, a fire or explosion may result, causing property damage, personal injury or death.

IMPORTANT NOTE: Read all safety instructions before using this appliance.

- Installation and service must be performed by a qualified installer, service agency or the gas supplier.
- Warranty service must be performed by Wolf factory certified service.
- Do not store or use gasoline or other flammable vapors and liquids in the vicinity of this or any other appliance.
- A ventilation hood or downdraft is recommended for use with the Wolf multi-function cooktop.

WHAT TO DO IF YOU SMELL GAS:

- Do not try to light any appliance.
- Do not touch any electrical switch.
- Do not use any phone in your building.
- Immediately call your gas supplier from a neighbor's phone. Follow the gas supplier's instructions.
- If you cannot reach your gas supplier, call the fire department.

IMPORTANT INSTRUCTIONS

GENERAL SAFETY REQUIREMENTS

- Read this use & care guide carefully before using your new multi-function cooktop to reduce the risk of fire, electric shock or injury to persons.
- Ensure proper installation and servicing. This appliance must be properly installed and grounded by a qualified technician.
- Have installer show you where the gas supply shut-off valve is located in your home. Learn how and where to turn off the gas to the cooktop.
- Before performing any service, turn off the gas supply by closing the gas shut-off valve and unplug the cooktop power cord from the electrical outlet.
- Always properly clean and maintain the cooktop as outlined in care recommendations on pages 12–13.
- Keep the igniter clean and dry for proper lighting and performance of the burner.
- In the event that the burner goes out and gas escapes, open a window or a door. Wait at least five minutes before using the cooktop.
- Keep appliance area clear and free from combustible material.
- Wear proper apparel. Never let loose clothing or other flammable materials come in contact with the burner while in operation. Fabric may ignite and cause personal injury.
- **IMPORTANT:** Do not install a ventilation system that blows air downward toward this gas cooking appliance. This type of ventilation system may cause ignition and combustion problems with this gas cooking appliance resulting in personal injury or unintended operation.
- Always use dry pot holders when removing a pan from the cooktop. Wet or damp pot holders can cause steam burns. Do not use a towel or bulky cloth in place of pot holders.
- When deep fat frying, be sure the pan is large enough to accommodate the food without overflowing when fat begins to bubble. Heat fat slowly. Never leave a deep fat fryer unattended. Avoid deep fat frying moist or frost-covered foods. Foods with a high water content may cause the hot fat to spatter. Use a thermometer to avoid heating the fat above the flash point.
- When cooking, set the burner control so the flame heats only the bottom of the pan and does not extend beyond the bottom of the pan.
- Choose pans with easily grasped handles that will stay cool while cooking. Refer to cookware selection on page 14.
- Always turn panhandles inward so they do not extend over adjacent work areas or the edge of the cooktop.
- Always check the position of the control knob to make certain the cooktop is off when you are finished cooking.
- Always light the burner prior to placing a pan on the burner grate. Also, turn the control knob to the OFF position before removing a pan from the grate.
- Start the ventilation hood approximately five minutes before cooking. This establishes an air curtain and improves the capture of vapor and moisture.
- Do not repair or replace any part of the cooktop unless specifically recommended in literature accompanying this appliance. All service should be referred to a qualified technician.

IMPORTANT INSTRUCTIONS

GENERAL SAFETY REQUIREMENTS

- Do not obstruct the flow of air. Your kitchen must have an adequate supply of fresh air to ensure proper combustion and ventilation.
- Do not use aluminum foil to line any part of the cooktop.
- Never use the cooktop to warm or heat the room.
- Do not block or obstruct the hole in the cooktop surface below the control knob. Blocking the hole may affect burner operation and may result in a hazard.
- When using the cooktop, do not touch the grate, burner or any other parts in proximity to the flame. These components may be hot enough to cause burns.
- If the cooktop is near a window, do not use long curtains as a window treatment, as they could blow over the cooktop and create a fire hazard.
- Do not leave children alone or unattended in the area where the cooktop is in use. Never allow children to sit or stand on the appliance. Do not let children play with the cooktop.
- Do not store items of interest to children above or at the back of the cooktop, as they could climb on the appliance to reach items and be injured.
- Do not use water on grease fires. Smother the flame or use a dry chemical or foam-type extinguisher.
- Never leave the appliance unattended when in use. Boilovers and greasy spills may smoke or ignite.
- Do not cover the burner and grate with anything except properly selected utensils. Decorative covers should not be used.
- Do not heat unopened food containers, such as baby food jars and cans. Pressure build-up may cause the container to burst and cause injury.
- Do not store flammable materials near burners or let grease or other flammable substances accumulate on the cooktop.
- Do not use abrasive or caustic cleaners or detergents on this appliance, as these may cause permanent damage. Do not use aerosol cleaners, as these may be flammable or cause corrosion of metal parts.
- Do not store or use gasoline or other flammable vapors and liquids in the vicinity of this or any other appliance.
- Do not clean the cooktop while it is still hot. If using a damp sponge or cloth, wait until the cooktop has cooled sufficiently to prevent steam burns. Also, some cleaners can produce harmful or unpleasant fumes if applied to hot surfaces. Refer to care recommendations on pages 12–13.
- Do not allow aluminum foil, plastic, paper or cloth to come in contact with the hot burner or grate. Do not allow pans to boil dry.

SAFETY PRECAUTIONS

⚠ WARNING

TO REDUCE THE RISK OF INJURY TO PERSONS IN THE EVENT OF A COOKTOP GREASE FIRE, OBSERVE THE FOLLOWING:

Smother flames with a close-fitting lid, baking sheet or other metal tray; then turn off the gas burner. Be careful to prevent burns. If the flames do not go out immediately, evacuate and call the fire department.

Do not use water on grease fires.

Never pick up a flaming pan, you may be burned.

USE AN EXTINGUISHER ONLY IF:

- You know you have a class ABC extinguisher and you already know how to operate it.
- The fire is small and contained in the area where it started.
- The fire department is being called.
- You can fight the fire with your back to an exit (NFPA fire safety tips).

CALIFORNIA PROPOSITION 65

⚠ WARNING

Burning gas cooking fuel generates some by-products that are on the list of substances known to cause cancer or reproductive harm. To minimize exposure to these substances, always operate this unit according to the instructions contained in this guide and provide good ventilation.

COMMONWEALTH OF MASSACHUSETTS

- Installations and repairs must be performed by a qualified or licensed contractor, plumber or gas fitter, qualified or licensed by the state, province or region where this appliance is being installed.
- Use only gas shut-off valves approved for use within the state, province or region where this appliance is being installed.
- A flexible gas connector, when used, must not exceed 3' (.9 m).

Multi-Function Cooktop Features

- Integrated design allows for installation of multiple cooktops or modules.
- Crafted of heavy-duty stainless steel.
- High-output 22,000 Btu (6.5 kW) burner concentrates its flame in precisely the right spot for stir-frying.
- Dual-stacked sealed burner with flame recognition and automatic reignition for safety and ease of use.
- Illuminated control panel with cool touch control knob.
- Two interchangeable, porcelain-coated cast iron burner grates—wok grate and low-profile grate.
- Deep seamless burner pan for easy cleanup.
- Individual spark ignition system.
- CSA certified for US and Canada.
- Two and five year residential warranty—exclusions apply, see warranty at the end of this guide.

OPTIONAL ACCESSORIES

Optional accessories are available through your authorized Wolf dealer. For local dealer information, visit the find a showroom section of our website, wolfappliance.com.

- Filler strip for installation with another cooktop or module.
- Support bracket for installation with another module and downdraft.
- High altitude conversion kit.

MULTI-FUNCTION COOKTOP

Model IM15/S

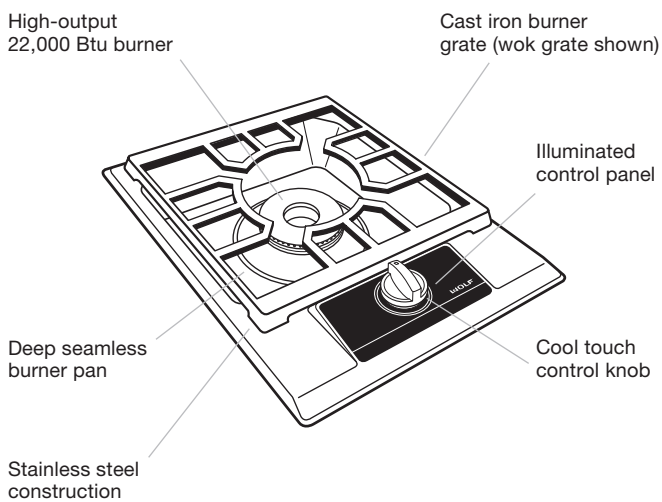

Control Panel

The control panel of your multi-function cooktop is illuminated for an instant visual indication that the burner is in use. It is a safety signal reminding you that the flame is on and active.

CONTROL KNOB

It is normal for the control knob to be slightly raised above the surface. This space is an air inlet necessary for good combustion of gas. The knob rests on a valve stem with a rubber grommet at the base. This design prevents liquid spills from dripping into the controls below the burner. Refer to the illustration below.

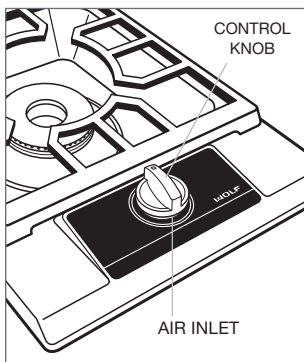

Touch control panel.

Surface Burner

A spark electrode ignites the surface burner. This control eliminates the need for a continuous open flame pilot. For added safety and convenience, the burner is designed with an electronic reignition system. This feature enables the burner to automatically relight in the event it is accidentally extinguished.

FLAME HEIGHT AND APPEARANCE

Select a flame that is just high enough to maintain the desired cooking speed and is sized to fit the base diameter of the pan. Never extend the flame beyond the base of the pan.

A natural gas flame should be blue with a deeper blue core. There should be minimal trace of a yellow flame. A yellow flame indicates an improper mixture of air and gas or impurities in the gas supply to the cooktop. If this occurs consistently, call Wolf factory certified service to adjust the mixture. With LP gas, some yellow tipping to the flame is acceptable and may not require an adjustment.

MANUAL LIGHTING

In case of a power outage, you can relight the surface burner manually. Turn the control knob to HIGH, then light the burner using a BBQ lighter.

Multi-Function Cooktop Operation

INITIAL START-UP

Before using for the first time, clean your multi-function cooktop thoroughly with hot water and a mild detergent. Rinse and dry with a soft cloth. This removes any residual oil and grease left on the surface from the manufacturing process. Refer to care recommendations on pages 12–13.

IMPORTANT NOTE: A small amount of smoke and odor may be noticed during the initial break-in period.

To light the burner, push down and turn the control knob counterclockwise to the HIGH setting. You will hear a clicking sound and see the burner ignite. Once the burner is lit, continue turning the knob counterclockwise to any one of the settings—HIGH through LOW.

Using the Multi-Function Cooktop

STIR-FRYING

Stir-frying is a method of cooking that uses very little oil and involves continuous stirring. Because food is cooked so rapidly, color, flavor, texture and nutrition are preserved.

- 1) Prepare all ingredients in advance.
- 2) Heat the wok over HIGH heat until hot. Drizzle in oil. Heat until oil is hot.
- 3) Add meat to wok. Cook and stir until done. Remove from wok.
- 4) Add vegetables requiring the longest cooking time to the wok. Then add remaining vegetables. Cook and stir until crisp-tender.
- 5) Return meat to wok.
- 6) Add sauce. Stir to coat.

STIR-FRYING TIPS

- Never leave food unattended while stir-frying.
- Cut ingredients into uniform pieces. Pieces of the same size will cook at the same rate.
- Use oil that can withstand high heat, like peanut oil.
- Don't crowd foods. Too much food in the wok can cause stewing and steaming rather than stir-frying.
- Use hot oil; when hot enough it will ripple as the wok is tilted from side to side.
- Keep food moving at all times.

STEAMING

Steaming helps vegetables retain nutrients. A wok with a lid or a bamboo steamer is needed to steam food.

- 1) Pour 1¹/₂" (38) to 2" (51) of hot water into wok.
- 2) Place wire rack or bamboo steamer into wok. Water level should not touch rack or steamer.
- 3) Cover; bring to a boil.
- 4) Add food; cover. Do not let wok boil dry. Add more water as needed.
- 5) Cook until food tests done.

STEAMING TIPS

- Never leave food unattended while steaming.
- If you don't have a wok steamer rack, use a round cooling rack instead.
- Don't lift the lid until near the end of the cooking time; this will result in increased cooking time.

Care Recommendations

COOKTOP CLEANING TIPS

- Wait until surfaces are cool before cleaning.
- For best results, wipe up spills and splatters as they occur and immediately after the cooktop has cooled. If splatters are allowed to cook on, they may permanently damage or stain the finish.
- Use a spray degreaser to remove fingerprints and greasy splatters. Spray on a cloth and wipe the surface. Buff dry immediately to avoid streaking. For hard water stains, use white vinegar and water.
- If in doubt about using one of your cleaners, check the label. To check if it is safe to use on your cooktop, try a small amount on an inconspicuous area.
- Use caution when spraying cleaners. Some contain caustic ingredients that can damage adjacent parts and finishes. Protect the adjacent parts by masking them off to avoid damage by overspray.
- Do not spray cleaners on the control knob or igniter.
- Refer to the care recommendations for specific cooktop components.

IMPORTANT NOTE: Make sure the multi-function cooktop is off and all surfaces are cool before cleaning any part of the unit.

STAINLESS STEEL SURFACES

IMPORTANT NOTE: Do not use abrasive cleaners; they will permanently scratch stainless steel surfaces. Salt and some cooking liquids may pit and stain the surface. Remove these splatters immediately.

Use a spray degreaser to remove fingerprints and greasy splatters. Spray on a cloth and wipe the surface. Buff dry immediately to avoid streaking. For hard water stains, use white vinegar and water.

For general cleaning, use a soft, nonabrasive stainless steel cleaner like Signature polish and apply with a soft lint-free cloth. To bring out the natural luster, lightly wipe the surface with a water-dampened microfiber cloth followed by a dry polishing chamois. All work should follow the grain direction of the finish. Better results are obtained by keeping the cloth in continuous contact with the stainless steel.

Signature polish is available from Signature Limited Laboratory, P. O. Box 13436, Dayton, Ohio 45413, or call 877-376-5474.

Care Recommendations

GENERAL CLEANING

Burner pan.

- Do not use abrasive cleaners; they will permanently scratch porcelain enamel surfaces. Use a clean cloth or sponge and wipe the surface with warm water and a mild detergent. Rinse and dry immediately.
- Use a spray degreaser to remove fingerprints and greasy spatters. Spray on a cloth and wipe the surface. Buff dry immediately to avoid streaking. For hard water stains, use white vinegar and water.

Burner grate.

- Remove the burner grate and clean with a nonabrasive cleaner such as liquid detergent and hot water, or a paste of baking soda and water. Do not immerse in water. Spray degreasers and mild abrasive cleaners may be used.

Burner head and base.

- Wash in warm water and liquid detergent or mild abrasive cleaner. Rinse and dry.

Spark igniter.

- Keep dry; never spray water or cleaner directly on the igniter. When cleaning the burner, avoid contact with the igniter.

Control knob.

- To remove, slip the edge of a dish towel under the knob; pull edges together. Using the towel for leverage, lift up, pulling the knob off the valve stem.
- Wipe the control knob with a damp cloth and mild detergent and water; rinse and dry. Do not soak the knob or use abrasive cleaners, they will scratch the finish and remove markings.

Control panel.

- Use a spray degreaser to remove fingerprints and food soils. Spray on a cloth and wipe the panel. Do not spray directly on the panel near the valve stem.

Cookware Selection

For best results, we recommend medium- to heavy-weight cookware. Pans should have a flat base, metal handle and good-fitting cover. Look for pans that are made of materials with good heat conductivity, such as aluminum and copper. Use the following guidelines when selecting cookware:

- Select deep pans with high sides rather than ones with wide bases and low sides to avoid boilovers.
- Cover pans while cooking to improve cooking efficiency. Water boils faster, using less fuel, and the kitchen stays cooler.
- Select lower flame settings when using pans made of cast iron, enameled steel or glass ceramic, or pans coated with a nonstick finish. High heat may cause hot spots, scorching and burning.
- Pans with oversize bases that extend beyond the cooktop frame should not be used. On high settings, heat may be trapped beneath the pan causing permanent damage to the surface finish.

WOKS

Wok cooking is versatile and quick. The bowl-like pan distributes heat evenly and is perfect for stir-frying, steaming, stewing and braising.

A wok with a diameter of up to 18" (457) can be used with the wok grate provided with your multi-function cooktop. Woks are available in carbon steel, stainless steel and aluminum. If possible, purchase a wok with a lid. Follow the wok manufacturer's directions for cooking methods.

To prepare the wok for cooking, wash in soapy water and dry thoroughly. If the wok is made of carbon steel, the wok must be seasoned to prevent rusting. To season, wipe the inside of the wok with oil. Heat over high heat until a dark film forms. Do not remove the film.

Use the wok grate provided with your multi-function cooktop for wok cooking. The wok should be centered on top of the burner when placed on the wok grate.

IMPORTANT NOTE: When cooking with a wok, make sure that the wok is sitting level on the grate to prevent spills and uneven cooking.

Chicken Vegetable Stir-Fry with Oyster Glaze and Peanuts

Makes 4 to 6 servings

Ingredients:

2 Tbsp (30 ml) vegetable oil
2 cups (300 g) chicken strips, beef strips or shrimp
1 cup (150 g) sliced shiitake mushrooms
2 cups (300 g) pea pods, cleaned and trimmed
3 cups (450 g) broccoli flowerettes
1 cup (150 g) sliced red pepper, cut in half
1 cup (150 g) sliced yellow pepper, cut in half
2 scallions, thinly sliced on the bias
1 cup (240 ml) oyster glaze (see recipe)
1/4 cup (40 g) chopped dry roasted peanuts

Optional:

8 cups (1.5 kg) white rice
Oyster glaze

METHOD

Place a cast iron or 18" (457) steel wok on Wolf multi-function cooktop over high heat. Heat for 9 to 10 minutes or until very hot. Assemble ingredients in separate bowls. When the wok is preheated, add the oil to the wok and quickly add chicken and mushrooms, stirring for 1 minute and allowing them to brown. Add remaining vegetables and stir for about 5 minutes. Stir in the oyster glaze and heat for 30 seconds. Carefully remove meat and vegetables from the wok. Serve immediately with rice and glaze on the side, if desired.

Oyster Glaze for Stir-Fry

Makes 2¹/₃ cups (560 ml)

Ingredients:

1¹/₂ Tbsp (25 ml) chopped garlic
1¹/₂ Tbsp (25 ml) chopped ginger
³/₄ cup (180 ml) oyster sauce
1 cup (240 ml) water
2 Tbsp (30 ml) cornstarch
¹/₄ cup (60 ml) water
¹/₄ cup (60 ml) sesame oil

METHOD

Combine garlic, ginger, oyster sauce and 1 cup (240 ml) water in 2-quart (2 L) bowl. In 1-cup (240 ml) glass measure, mix cornstarch and ¹/₄ cup (60 ml) water. Whisk into the oyster sauce mixture. Stir in sesame oil. Refrigerate. Stir before each use.

Wok Seared Salt & Pepper Shrimp

Makes 3 to 4 servings

Ingredients:

1¹/₂ lbs (.7 kg) (16-20 per pound count) large raw shrimp,
peeled and de-veined
2 Tbsp (30 ml) vegetable oil
1¹/₂ tsp (2 ml) kosher salt
Large pinch cracked pepper
1¹/₂ tsp (2 ml) sugar

METHOD

Place a cast iron or 18" (457) steel wok on the Wolf multi-function cooktop over high heat. Heat for 10 minutes. Toss shrimp with the other ingredients. When the wok is hot, carefully add shrimp to the wok and stir with a wooden spoon, allowing the shrimp to brown. Cook and stir for 2 to 3 minutes. Remove the shrimp from the wok and serve immediately.

Troubleshooting

If your Wolf multi-function cooktop is not operating properly, use the following troubleshooting guide before calling Wolf factory certified service. This guide will save you time and trouble and may help you avoid the expense of a service call.

Multi-function cooktop does not operate.

- Check the household fuse or circuit breaker to see if it has been blown or tripped. A power outage may also have caused a disruption in service.
- Verify that the electrical connection to the cooktop has not been disconnected.

Burner fails to ignite.

- Igniter is damp. Allow it to dry completely.

Food boils out of the pan and overflows.

- Heat setting is too high or pan is too small for its contents.

Food boils or burns more in one area of a pan.

- Pan is not centered above the burner or base of pan does not rest flat on the burner grate.
- Pan does not conduct heat evenly.

Water does not come to a boil fast enough.

- Cover pan for most efficient use of the high setting.
- Diameter of pan is too large or base of pan is warped.

Food cooks too slowly when stir-frying or sautéing.

- Too much food added at one time; stir-fry or sauté in batches.
- Size of food pieces is too large or temperature of food is colder than usual.
- Pan does not conduct heat evenly.

Service Information

When requesting information, literature, replacement parts or service, always refer to the model and serial numbers of your multi-function cooktop. Both numbers are listed on the product rating plate, located on the underside of the cooktop. Refer to the illustration on page 3. Record the rating plate information below for future reference.

Model Number: _____

Serial Number: _____

Installation Date: _____

Wolf Factory Certified Service: _____

Phone: _____

Authorized Wolf Dealer: _____

Phone: _____

BEFORE CALLING FOR SERVICE

Before calling Wolf factory certified service, refer to the troubleshooting guide on page 17.

PRODUCT REGISTRATION

Register your new Wolf product today so that we may ensure your satisfaction. You may register by one of the following options:

- 1) Mail in the completed Wolf product registration card.
- 2) Register online at wolfappliance.com.
- 3) Register by phone by calling Wolf customer care at **800-222-7820**.

The model and serial numbers of your unit are printed on the enclosed Wolf product registration card. If you provide us with your e-mail address, we will send you exciting new product updates and recipes as they become available, along with information on special events.

The information and images in this guide are the copyright property of Wolf Appliance, Inc. Neither this guide nor any information or images contained herein may be copied or used in whole or in part without the express written permission of Wolf Appliance, Inc. ©Wolf Appliance, Inc. all rights reserved.

Wolf, Wolf & Design, Wolf Gourmet, W & Design and the color red as applied to knobs are registered trademarks and service marks of Wolf Appliance, Inc. Sub-Zero, Sub-Zero & Design, Dual Refrigeration, Constant Care and The Living Kitchen are registered trademarks and service marks of Sub-Zero, Inc. (collectively, the "Company Marks.") All other trademarks or registered trademarks are property of their respective owners in the United States and other countries.

Wolf Appliance Products Limited Warranty

FOR RESIDENTIAL USE ONLY

FULL TWO YEAR WARRANTY*

For two years from the date of original installation, your Wolf Appliance product warranty covers all parts and labor to repair or replace, under normal residential use, any part of the product that proves to be defective in materials or workmanship. All service provided by Wolf Appliance under the above warranty must be performed by Wolf factory certified service, unless otherwise specified by Wolf Appliance, Inc. Service will be provided during normal business hours.

LIMITED FIVE YEAR WARRANTY

For five years from the date of original installation, Wolf Appliance will repair or replace the following parts that prove to be defective in materials or workmanship: gas burners (excluding appearance), electric heating elements, blower motors (ventilation hoods), electronic control boards, magnetron tubes and induction generators. The part(s) will be repaired or replaced, free of charge, with the owner paying for all other costs including labor. All service provided by Wolf Appliance under the above warranty must be performed by Wolf factory certified service, unless otherwise specified by Wolf Appliance, Inc. Service will be provided during normal business hours.

TERMS APPLICABLE TO EACH WARRANTY

The warranty applies only to products installed for normal residential use. The warranty applies only to products installed in any one of the fifty states of the United States, the District of Columbia or the ten provinces of Canada. This warranty does not cover any parts or labor to correct any defect caused by negligence, accident or improper use, maintenance, installation, service or repair.

THE REMEDIES DESCRIBED ABOVE FOR EACH WARRANTY ARE THE ONLY ONES THAT WOLF APPLIANCE, INC. WILL PROVIDE, EITHER UNDER THIS WARRANTY OR UNDER ANY WARRANTY ARISING BY OPERATION OF LAW. WOLF APPLIANCE, INC. WILL NOT BE RESPONSIBLE FOR ANY CONSEQUENTIAL OR INCIDENTAL DAMAGES ARISING FROM THE BREACH OF THIS WARRANTY OR ANY OTHER WARRANTY, WHETHER EXPRESS, IMPLIED OR STATUTORY.

Some states do not allow the exclusion or limitation of incidental or consequential damages, so the above limitation or exclusion may not apply to you. This warranty gives you specific legal rights and you may also have other legal rights that vary from state to state.

To receive parts and/or service and the name of Wolf factory certified service nearest you, contact Wolf Appliance, Inc., P.O. Box 44848, Madison, WI 53744; check the contact & support section of our website, wolfappliance.com or call 800-222-7820.

*Stainless steel doors, panels, handles, product frames and interior surfaces are covered by a limited 60-day parts and labor warranty for cosmetic defects.

*Replacement filters for ventilation hood recirculating kits are not covered by the product warranty.





WOLF APPLIANCE, INC. P. O. BOX 44848 MADISON, WI 53744 WOLFAPPLIANCE.COM 800.222.7820

817486 REV-B

12/2013

