



48" Professional Side-by-Side

Born of 100% steel (and a good bit of bravado), model 648PRO is a true masterpiece of preservation. Its sculpted metal, dual refrigeration with three evaporators and advanced controls marry performance and design in a bold new way for home refrigeration. So it not only keeps foods magnificently fresh, it brings the whole kitchen tastefully up to date. Model 648PRO can be built-in or used in a free-standing application.



Model 648PRO shown in a free-standing application.

FEATURES

- Handles coordinate with Wolf ranges.
- Stainless steel interior and exterior.
- Dual refrigeration system with two compressors and three evaporators keeps food fresher longer.
- Microprocessor and interior touch control panel with exterior digital temperature display.
- Ceiling lighting in both upper cabinets with LED side lighting in refrigerator.
- Adjustable spill-proof glass shelves.
- Slide-out stainless steel bins fit neatly under refrigerator glass shelves.
- Touch-and-glide crisper drawer with tight-sealing clear cover.
- Interior drawer dividers can be used in either refrigerator drawer.
- Precision-built auto-close door hinges.
- Easy-access flip-up grille.
- Automatic ice maker with advanced water filtration system.

INTERIOR FEATURES

- **Refrigerator (door and two drawers)**
 - 3 Adjustable Glass Shelves
 - 1 Stationary Glass Shelf
 - 2 Adjustable Stainless Steel Slide-Out Bins
 - 1 Glass Crisper Lid
 - Interchangeable Drawer Dividers
- **Freezer (door and two drawers)**
 - Automatic Ice Maker
 - Water Filtration Filter
 - 3 Adjustable Stainless Steel Shelves
 - 1 Stationary Stainless Steel Shelf
 - Stainless Steel Ice Bucket
- Exterior Temperature Display
- Auto-Close Advanced Hinge System

ACCESSORIES

- Stainless steel side panels and top for freestanding application.
- Stainless steel side panel.
- Stainless steel front and side kickplates.
- Slide-out stainless steel refrigerator bins.
- Refrigerator drawer dividers.
- Replacement water filter.
- 90° door stop.

Accessories are available through your Sub-Zero dealer. For local dealer information, visit the find a showroom section of our website, subzero.com.



Slide-out bins.



Glass crisper lid.





48" Professional Side-by-Side

OVERALL DIMENSIONS

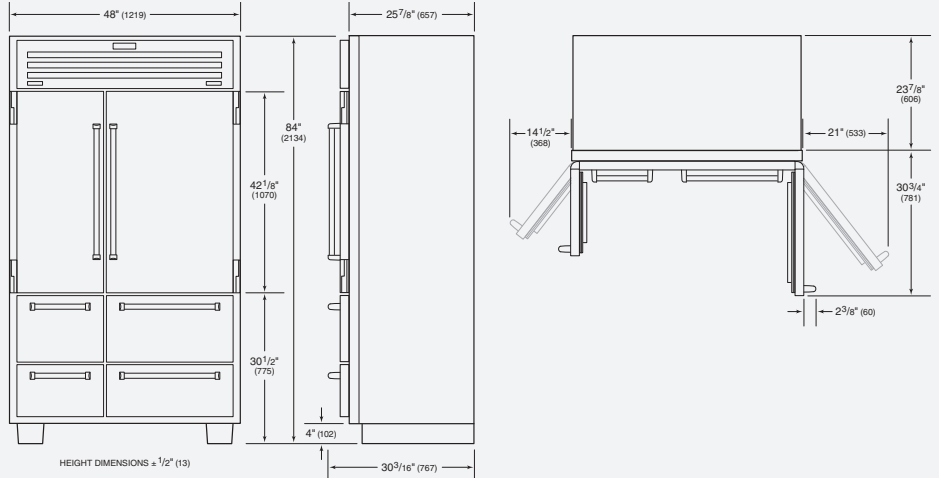

Unit dimensions may vary by $\pm 1/8"$.

Dimensions in parentheses are in millimeters unless otherwise specified.

SPECIFICATIONS

| | |
|-----------------------------|--|
| Overall Width | 48" |
| Overall Height | 84" |
| Overall Depth | 24" |
| Door Swing Clearance | 30 3/4" |
| Refrigerator Capacity | 18.4 cu ft |
| Freezer Capacity | 11.7 cu ft |
| Finished Opening (standard) | 47 1/2" W x 83 3/4" H x 24" D |
| Finished Opening (flush) | 48" W x 84 1/8" H x 26" D |
| Minimum Height Required | 83 1/2" |
| Electrical Requirements | 115 V AC, 60 Hz 15 amp dedicated circuit |
| Plumbing Requirements | 1/4" OD copper, braided stainless steel or PEX tubing 35-120 psi |
| Shipping Weight | 860 lbs |

INSTALLATION SPECIFICATIONS

Standard and Flush Built-In

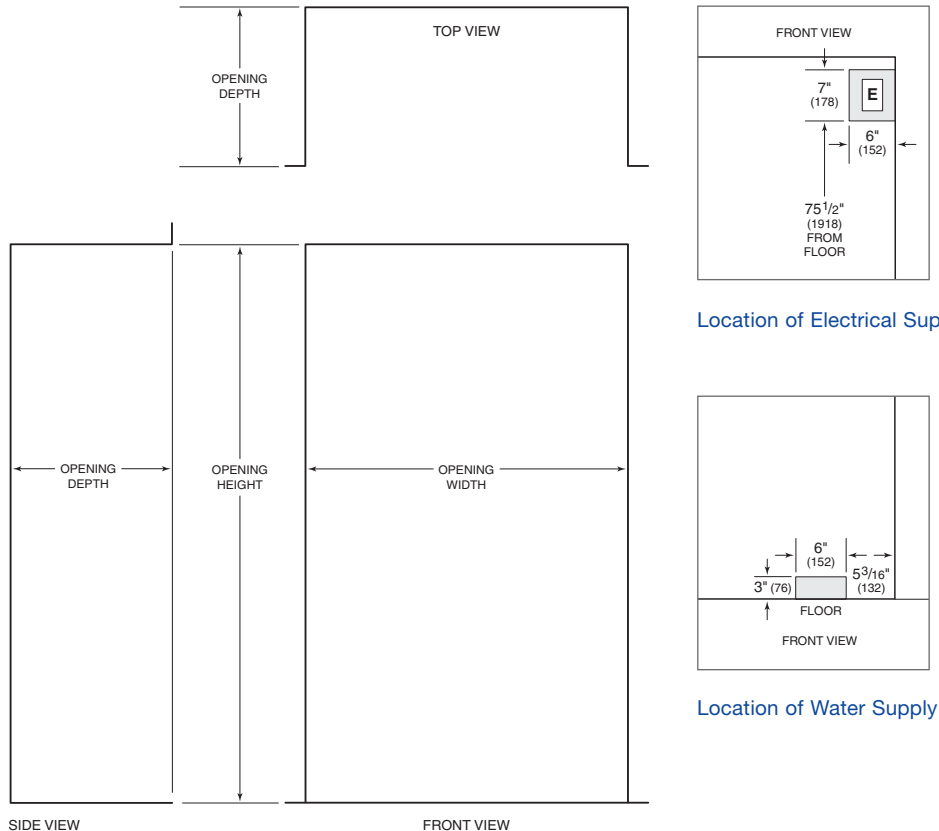

INSTALLATION NOTES

Model 648PRO can be used free-standing or installed as a standard or flush built-in application. For standard built-in installations, the face frame of the unit will extend 2" beyond cabinetry. In flush built-in installations, the front of the face frame will be flush with surrounding cabinetry.

Complete installation specifications, including panel sizes, can be found on our website, subzero.com/specs.

| Opening Dimensions | Standard | Flush |
|--------------------|----------|---------|
| Opening Width | 47 1/2" | 48" |
| Opening Height | 83 3/4" | 84 1/8" |
| Opening Depth | 24" | 26" |