



30" Unframed Induction Cooktop

Induction cooking has been used in Europe for decades by professionals and homeowners demanding the best in performance. They are 90-95% energy efficient; as a result, no heat is wasted because energy is supplied directly to the cooking vessel. With Wolf's unframed induction cooktops there's no stainless steel trim, just the sophisticated, minimalist exterior subtly patterned design to hide any unsightly scratches.



Model CT30IU shown in flush mounted installation.

FEATURES

- Can be mounted flush with top of countertop or as a frameless installation sitting on top of the countertop surface.
- Easy-to-clean black ceramic glass surface is resistant to scratching, staining, impact and heat.
- Induction elements heat cookware, not the glass, for a cooler, safer cooking surface.
- Four high-efficiency induction elements deliver power and control.
- Maximum element power: (2) 1800 W with 3000 W boost and (2) 1200 W.
- True simmer setting on two elements.
- Melt setting on two elements.
- Cookware sensing—elements will not be energized without an induction-compatible pan on the cooktop surface.
- Hi-Power mode boosts power on 1800 W elements by diverting power from adjacent element.
- Temperature limiter to ensure that safe operating temperature of ceramic glass is never exceeded.
- Illuminated touch controls with graduated control lighting and adjustable sound frequency and volume.
- Hot-surface indicator light in control panel.
- Lock mode—cooktop will be locked so that no elements can be turned on.
- Universal OFF turns all elements off.
- Countdown timer with 1 to 99 minute range.

HOW DOES INDUCTION COOKING WORK?

The electricity flows through a coil to produce a magnetic field under the ceramic cooktop. When a cast iron or magnetic stainless steel pan is placed on the ceramic glass surface, currents are induced in the cooking utensil and instant heat is generated due to the resistance of the pan. Induction only works with cooking vessels made of magnetic materials, such as cast iron and magnetic stainless steel (it will not work with aluminum or copper pots).

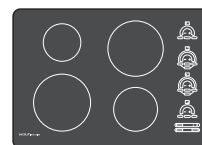

Model CT30IU



Hi-Power boost control.



30" Unframed Induction Cooktop

OVERALL DIMENSIONS

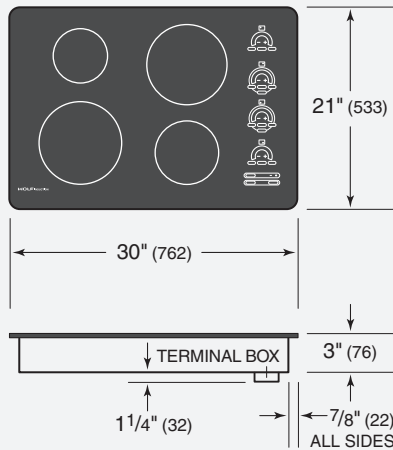

Unit dimensions may vary by $\pm 1/8$ " (3).

SPECIFICATIONS

Overall Width	30"
Overall Height	3"
Overall Depth	21"
Induction Elements	Four
Countertop Cut-Out Width	28 ³ / ₈ "
Countertop Cut-Out Depth	19 ³ / ₈ "
Maximum Element Power	(2) 1200 W (2) 1800 W with 3000 W boost
Element Diameters	5 1/2", 6 3/4" and (2) 8 3/4"
Electrical Requirements	240/208 V AC 50/60 Hz, 40 amp circuit
Conduit	4" flexible 3-wire
Electrical Rating	7.2 kW at 240 V 6.3 kW at 208 V
Shipping Weight	48 lbs

INSTALLATION SPECIFICATIONS

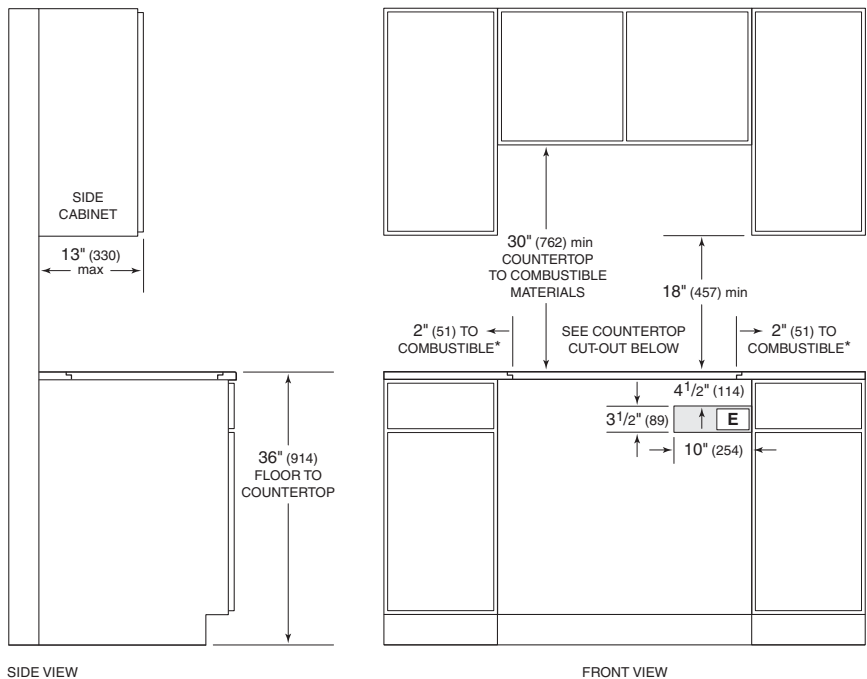

*Minimum clearance from cooktop cut-out to combustible materials up to 18" (457) above countertop.

NOTE: Electrical location applies only to installation with built-in oven.

INSTALLATION NOTES

Unframed induction cooktops can be mounted flush with the top of the countertop or as a frameless installation sitting on top of the countertop surface.

Complete installation specifications can be found on our website, wolfappliance.com.

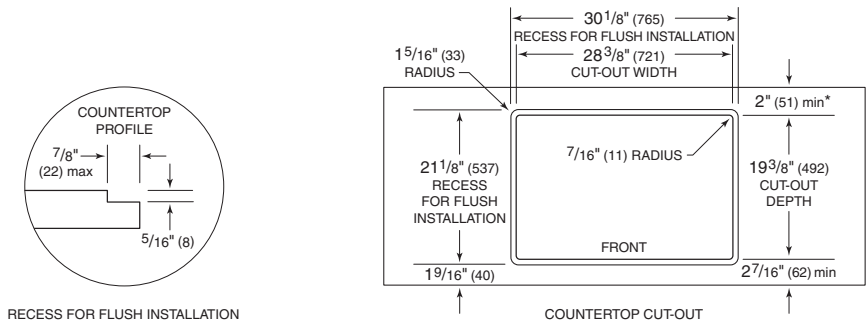

RECESS FOR FLUSH INSTALLATION

COUNTERTOP CUT-OUT

Dimensions in parentheses are in millimeters unless otherwise specified.