

IW-30CI



FEATURES

Accepts custom panels for an integrated look within cabinetry or stainless-steel accessory panels and handles to match other Sub-Zero, Wolf, and Cove products*

Offers any-occasion-86-bottle capacity

Store reds and whites in separate temperature zones that keep wines at proper serving temperatures, within one degree of setpoint

Refrigerator and freezer drawers create two additional temperature zones

Maintains constant, moderate humidity with dual evaporators so corks do not dry out

Shields wine from aging with UV-resistant glass door

Select the wine you want without agitating others with textured roller-glide shelves that do not vibrate

Freezer drawer yields ice automatically and "max ice" for additional production

Locks in cold air to ensure freshness with magnetic door seals

Locate your favorite bottles easily with LED lighting

Organize your collection with our inventory tile system

Connects to your home security system

ACCESSORIES

Reduced Toekick Divider

Stainless Steel Side Panel

Stainless Steel Top Panel

Water Filter

Water Filter

Dual Installation Kits

Stainless Steel Pro Handles

Stainless Steel Tubular Handles

Stainless Steel Drawer Panels With Pro Handles

Stainless Steel Drawer Panels With Tubular Handles

Stainless Steel Door Panels With Pro Handle

Stainless Steel Door Panels With Tubular Handle

Solid Panel Ready Door

Stainless Steel Dual Installation Kickplates

Accessories are available through an authorized dealer.
For local dealer information, visit subzero-wolf.com/locator.



HANDLE ACCESSORIES

PRO



TUBULAR



PRODUCT SPECIFICATIONS

Model	IW-30CI
Dimensions	30"W x 84"H x 24"D
Door Clearance	28 1/2"
Weight	481 lbs
Electrical Supply	115 VAC, 60 Hz
Electrical Service	15 amp dedicated circuit
Plumbing Supply	1/4" OD copper, braided stainless steel or PEX tubing
Plumbing Pressure	35–120 psi
Wine Storage Capacity	86 Bottles
Drawer Capacity	5.0 cu. ft.

DIMENSIONS

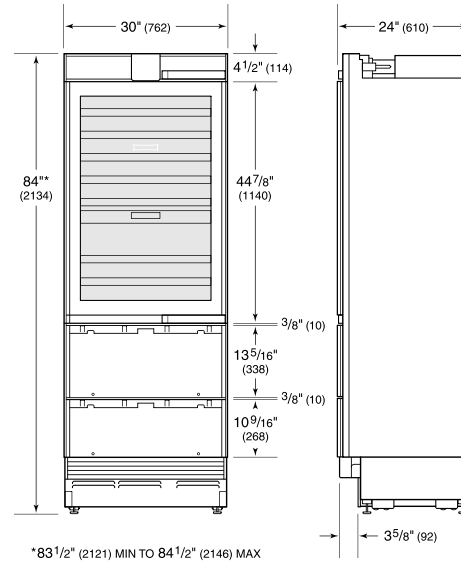

ELECTRICAL

PLUMBING

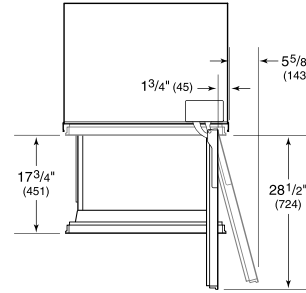
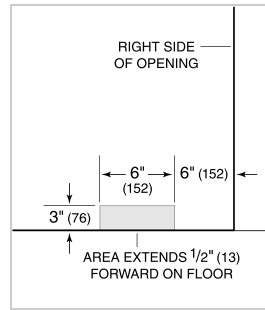
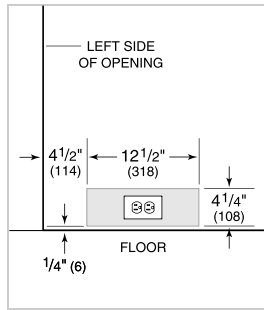

NOTE: The electrical outlet must be positioned with the grounding prong to the right of the thinner blades.

PANEL SPECIFICATIONS For complete panels specifications including width/height, weight requirements and thickness requirements visit subzero-wolf.com/reveal.

NOTE: Dimensions in parenthesis are in millimeters unless otherwise specified

INTERIOR VIEW



This illustration is intended for interior reference only and may not represent the exterior of the model being specified.

STANDARD INSTALLATION

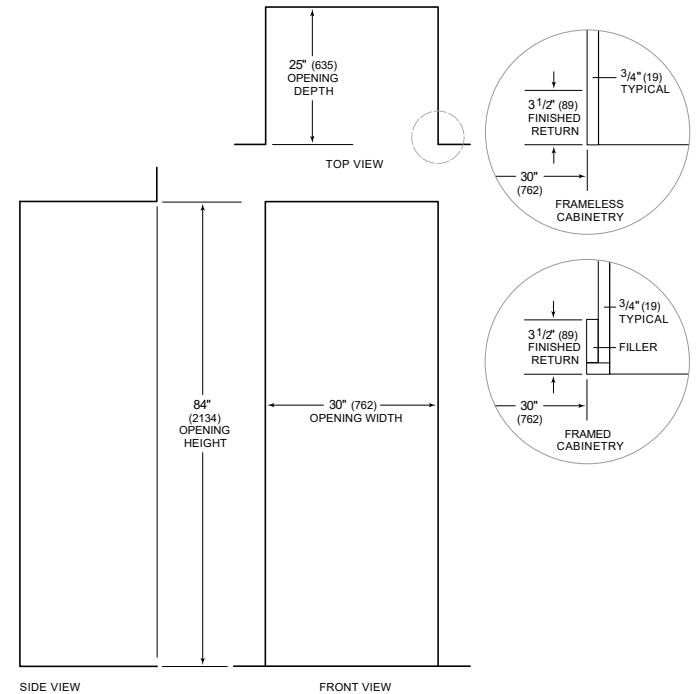

NOTE: 3 1/2" (89) finished returns will be visible and should be finished to match cabinetry